



*AIR
CONDITIONING*

*COMMERCIAL
REFRIGERATION*

HEAT PUMP



STANDARD
PRODUCT
CATALOGUE



SANHUA
SINCE 1984





Technical
information
sanhuaeurope.com

CHILLING IDEAS WORLDWIDE



SANHUA INTERNATIONAL EUROPE
info@sanhuaeurope.com

Certificate of registration
ISO 14001:2004



Certificate of registration
ISO 9001:2008



**BEST SUPPLIER
AWARDS**

B/S/H/



Note: Conditions could change without previous notice due to components updating or typing mistakes.

Sanhua declines any responsibility for a wrong product choice based on this table. Please make sure all your requirements are covered in our suggestion.

SUMMARY

SANHUA "Strive for perfection, Pursuit of excellence" **04**

4 WAY REVERSING VALVE SHF SERIES **08**

4 WAY REVERSING VALVE SHF (HP) SERIES **16**

ELECTRONIC EXPANSION VALVE DPF-T/S SERIES **20**

SOLENOID VALVE MDF SERIES **24**

SOLENOID VALVE FDF N/C SERIES **28**

SOLENOID VALVE FDF N/O SERIES **30**

THERMOSTATIC EXPANSION VALVE RFKA SERIES **34**

BALL VALVE SBV SERIES **39**

CHECK VALVE PISTON TYPE YCV SERIES **42**

SIGHT GLASS SYJ SERIES **46**

BRASS SERVICE VALVE SSV SERIES **50**

CHARGE VALVE TCJ SERIES **52**

UNI-FLOW FILTER DRIER DTG/L SERIES **54**

BI-FLOW FILTER DRIER STG/L SERIES **64**

COPPER FILTER DRIER BGQ SERIES **72**

FILTER DRIERS WITH REPLACEABLE CORE HTG SERIES **74**



STANDARD PRODUCTS

CE

RoHS

PED

UL

TÜV

VDE

CSA

 **SANHUA**

SANHUA

“Strive for perfection, Pursuit of excellence”

Sanhua is a leading HVAC&R manufacturer of controls and components with a global footprint and 30 years of experience. Our co-operation with the largest companies in the Automotive, Appliance and HVAC&R industry makes Sanhua a leading worldwide OEM supplier providing the highest quality components at the most competitive price.

Furthermore, strategic acquisitions by Sanhua of leading HVAC brands such as Ranco and Aweco and joint venture projects with Danfoss transformed Sanhua into one of the largest manufacturers of Expansion, Solenoid and Reversing Valves with annual valve sales exceeding 100 Million pieces.

SANHUA IS LISTED IN TOP 100 STRONGEST CHINESE INDUSTRIAL BRANDS.

After sustainable growth over the last 3 decades, Sanhua have made significant progress to introduce a comprehensive range of controls

and line components for the Commercial Air conditioning and Refrigeration Industries and to increase its service level coverage in the most important European markets.

QUALITY AND R&D

The company has a sufficient number of modern manufacturing equipment, advanced production engineering and effective control tools.

Products of Sanhua have passed many international and domestic safety certificates such as CQC, CE, TÜV, UL, VDE, and have gained trust and satisfaction from customers with reliable and continuous-improving quality.

ISO9001 Quality Management System
ISO14001 Environment Manag.System
QC080000 Hazardous Substance
ISO10012 Measurement Manag System**



*STANDARD PRODUCT FAMILIES

4 WAY REVERSING VALVE
SHF SERIES

4 WAY REVERSING VALVE
SHF (HP) SERIES

ELECTRONIC EXPANSION VALVE DPF-T/S SERIES

SOLENOID VALVE MDF SERIES

SOLENOID VALVE
FDF N/C SERIES

SOLENOID VALVE
FDF N/O SERIES

THERMOSTATIC EXPANSION VALVE RFKA SERIES

BALL VALVE SBV series

CHECK VALVE PISTON TYPE
YCV series



SIGHT GLASS SYJ series

BRASS SERVICE VALVE

SSV series

CHARGE VALVE TCJ series

UNI-FLOW FILTER DRIER

DTG/L series

BI-FLOW FILTER DRIER

STG/L series

COPPER FILTER DRIER

BGQ series

FILTER DRIERS WITH

REPLACEABLE CORE

HTG series

*customized and total product line is included in the general product catalogue.

GLOBAL FOOTPRINT & LOCAL SUPPORT



- Technical Service Hotline in 4 languages (English, Italian, German and Spanish)
- On site engineering support on request.
- Online Data Sheets and product catalogues.
- 72 hours delivery service for standard stocked items within the European Union.
- B2B Customer Platform, on line 24x7 order & stock management.



SANHUA *YOUR ROAD MAP TO THE ECO-DESIGN DIRECTIVE**

KEEPS YOU ONE STEP AHEAD OF THE COMING EFFICIENCY AND ENVIRONMENTAL EUROPEAN CHALLENGES



EEV Technology + Electronic Controls

- Improves HVAC α -R system efficiency up to **20%**
- DPF α -VPF series from 2kW to 1400kW
*75kW and 1400kW available in Quarter 4
- Advanced MSS (Minimum Stable Superheat) control logic



4 Way Reversing Valve

- Improves efficiency by **5%**
- SHF series 1kW to 420 kW
- Widest range in the market with Single Body Design



Inverter Controller for Large System

- Improves system efficiency up to **30%**
- Active Frequency Conversion Technology**
- Wide Range of voltage application

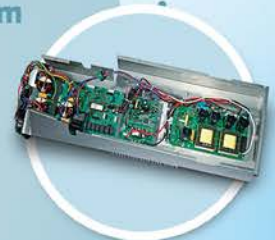

MCHE

- Improves efficiency by **30%**
- Refrigerant Charge Reduction by **30%** Environmental Friendly
- MCHE is lighter in weight, smaller in volume Compact Design



ADIRALES

*DIRECTIVE 2012/27/EU

ADVANCED
Technology & Solutions



CHILLING IDEAS WORLDWIDE

SANHUA INTERNATIONAL EUROPE
info@sanhuaeurope.com

2 out of 3 AC units are equipped
with a **SANHUA**
reversing valve

YEARLY SANHUA SUPPLIES OVER 50 MILLION
FOUR WAY REVERSING VALVES TO THE
COMMERCIAL AND RESIDENTIAL HVAC
INDUSTRY WORLDWIDE



DISCOVER
WHY

www.sanhuaeurope.com

- ✓ Improves efficiency by **5%**
- ✓ SHF series 1kW to 420 kW
- ✓ Widest range in the market with Single Body Design

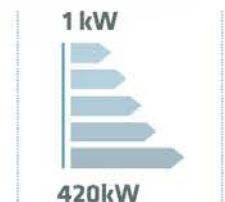

CHILLING *IDEAS* WORLDWIDE

SANHUA INTERNATIONAL EUROPE
info@sanhuaeurope.com

4 Way Reversing Valve

SHF series four-way reversing valves are applicable for heat pump systems such as central, unitary and room air conditioners to realize switching between cooling mode and heating mode by changing the flow path of refrigerant.

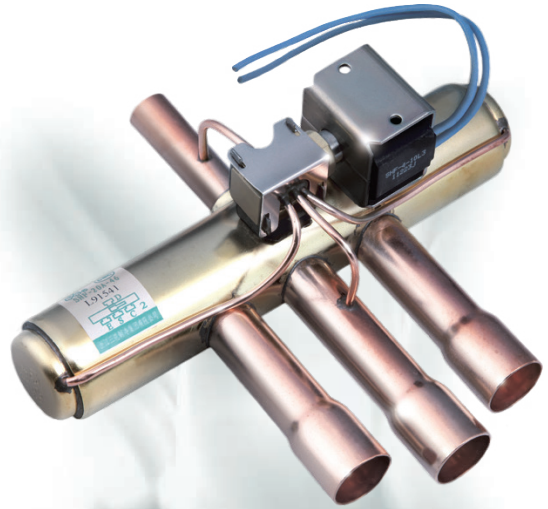

FEATURES

- WIDE APPLICATION RANGE
- SUITABLE FOR COOLING CAPACITIES FROM 3 TO 240KW (R407C, CONDITION 1)
- SEVERAL DESIGNS AVAILABLE

GENERAL SPECIFICATIONS

- Applicable for all common HCFC and HFC refrigerants such as: R22, R134a, R404A, R407C, R410A, R507A
- Medium temperature TS min./max.: -30°C / +120°C
- Ambient temperature min./max.: -30°C / +50 or +70°C (Depending on used coil)
- Relative humidity: 0 to 95% RH

- Max. operating pressure PS: 4,5 MPa (45 bar)
- Installation position:
 - Coil upwards or with body axis in horizontal alignment
 - Flow direction according to installation instruction
- Certifications: UL/CSA* and declaration according to LVD or PED

* SHF(L)-4H to SHF-50 valves, coil selection on request

NOMINAL OPERATING CONDITIONS

Nominal operating conditions	Condition 1:	Condition 2:
Condensing Temperature t_c	38°C	54,4°C
Evaporating Temperature t_o	5°C	7,2°C
Superheat Δt_{oh}	5K	5K
Subcooling Δt_{cu}	0K	5K

SHF SERIES

4 Way Reversing Valve

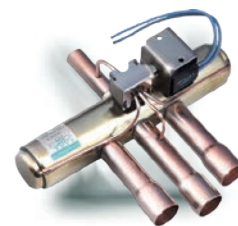

GENERAL CHARACTERISTICS

Valve Model	Part Number	Ø Port	Kv	Connections ODF		PS	OPD		PED category
		[mm]	[m³/h]	ØD	ØE/S/C		MAX	MIN	
				[inch]	[inch]	[MPa]	[MPa]	[MPa]	
SHF(L)-4H-23U	SHF-19001	8,0	1,7	5/16	3/8	4,5	3,1	0,25	3,3
SHF(L)-7H-34U	SHF-19002	11,1	3,1	3/8	1/2	4,5	3,1	0,25	3,3
SHF(L)-9H-35U	SHF-19003	11,5	3,6	3/8	5/8	4,5	3,1	0,3	3,3
SHF(L)-11H-45D1	SHF-19004	11,5	4,5	1/2	5/8	4,5	3,1	0,3	3,3
SHF-14-46	SHF-50001	13,5	6,3	1/2	3/4	4,5	3,1	0,3	3,3
SHF-14-47	SHF-50002	13,5	6,3	1/2	7/8	4,5	3,1	0,3	3,3
SHF-14-57	SHF-50003	13,5	6,3	5/8	7/8	4,5	3,1	0,3	3,3
SHF-20A-46	SHF-50004	15,6	7,9	1/2	3/4	4,5	3,1	0,3	3,3
SHF-20A-47	SHF-50005	15,6	7,9	1/2	7/8	4,5	3,1	0,3	3,3
SHF-20A-57	SHF-50006	15,6	7,9	5/8	7/8	4,5	3,1	0,3	3,3
SHF-20A-67	SHF-50007	15,6	7,9	3/4	7/8	4,5	3,1	0,3	3,3
SHF-20D-46-02	SHF-50008	17,2	9,9	1/2	3/4	4,5	3,1	0,3	3,3
SHF-35A-47	SHF-50009	20,0	13,9	1/2	7/8	4,5	3,1	0,3	3,3
SHF-35A-57	SHF-50010	20,0	13,9	5/8	7/8	4,5	3,1	0,3	3,3
SHF-35A-59	SHF-50011	20,0	13,9	5/8	1-1/8	4,5	3,1	0,3	3,3
SHF-35A-67	SHF-50012	20,0	13,9	3/4	7/8	4,5	3,1	0,3	3,3
SHF-35A-69	SHF-50013	20,0	13,9	3/4	1-1/8	4,5	3,1	0,3	3,3
SHF-35A-79	SHF-50014	20,0	13,9	7/8	1-1/8	4,5	3,1	0,3	3,3
SHF-35B-67-02	SHF-50015	20,9	14,7	3/4	7/8	4,5	3,1	0,3	3,3
SHF-50-911D2	SHF-50016	25,6	18,5	1-1/8	1-3/8	4,5	3,1	0,3	3,3
SHF(L)-70-810	SHF-50017	28,6	28,5	1	1-1/4	4,5	3,1	0,3	3,3
SHF(L)-70-810-01	SHF-50024	28,6	28,5	1	1-1/4	4,5	3,1	0,3	3,3
SHF(L)-100-1012	SHF-50018	34,8	40,5	1-1/4	1-1/2	4,5	3,1	0,3	I
SHF(L)-100-1012-01	SHF-50025	34,8	40,5	1-1/4	1-1/2	4,5	3,1	0,3	I
SHF(L)-140-1214	SHF-50019	41,0	58,4	1-1/2	1-3/4	4,5	3,1	0,3	I
SHF(L)-175-1217	SHF-50020	46,4	70,5	1-1/2	2-1/8	4,5	3,1	0,3	I
SHF(L)-210-1321	SHF-50021	50,0	84,4	1-5/8	2-5/8	4,5	3,1	0,3	I
SHF(L)-350-1721	SHF-50022	59,0	138,4	2-1/8	2-5/8	4,5	3,1	0,3	I
SHF(L)-420-2125	SHF-50023	69,0	177,0	2-5/8	3-1/8	4,5	3,1	0,3	I

SHF SERIES

4 Way Reversing Valve

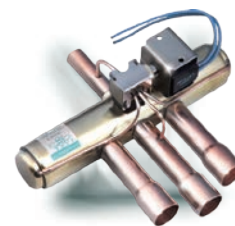

CAPACITY SELECTION

Valve Model ¹⁾	Part Number	Nominal Capacity (condition 1)							
		R407C ²⁾		R410A		R134a		R404A / R507	
		$\Delta P:$ 0,1 bar	$\Delta P:$ 0,2 bar	$\Delta P:$ 0,1 bar	$\Delta P:$ 0,2 bar	$\Delta P:$ 0,1 bar	$\Delta P:$ 0,2 bar	$\Delta P:$ 0,1 bar	$\Delta P:$ 0,2 bar
		[kW]	[kW]	[kW]	[kW]	[kW]	[kW]	[kW]	[kW]
SHF(L)-4H-23U	SHF-19001	3,8	5,3	4,5	6,4	2,9	4,2	3,2	4,6
SHF(L)-7H-34U	SHF-19002	7,0	9,9	8,5	12,0	5,5	7,8	6,0	8,5
SHF(L)-9H-35U	SHF-19003	8,0	11,3	9,6	13,6	6,3	8,9	6,8	9,7
SHF(L)-11H-45D1	SHF-19004	10,1	14,3	12,2	17,3	7,9	11,2	8,7	12,3
SHF-14-46	SHF-50001	13,9	19,7	16,8	23,8	10,9	15,5	11,9	16,9
SHF-14-47	SHF-50002	13,9	19,7	16,8	23,8	10,9	15,5	11,9	16,9
SHF-14-57	SHF-50003	13,9	19,7	16,8	23,8	10,9	15,5	11,9	16,9
SHF-20A-46	SHF-50004	17,6	24,8	21,2	30,0	13,8	19,5	15,0	21,3
SHF-20A-47	SHF-50005	17,6	24,8	21,2	30,0	13,8	19,5	15,0	21,3
SHF-20A-57	SHF-50006	17,6	24,8	21,2	30,0	13,8	19,5	15,0	21,3
SHF-20A-67	SHF-50007	17,6	24,8	21,2	30,0	13,8	19,5	15,0	21,3
SHF-20D-46-02	SHF-50008	22,1	31,3	26,7	37,8	17,4	24,6	19,0	26,8
SHF-35A-47	SHF-50009	30,9	43,7	37,3	52,8	24,3	34,3	26,5	37,5
SHF-35A-57	SHF-50010	30,9	43,7	37,3	52,8	24,3	34,3	26,5	37,5
SHF-35A-59	SHF-50011	30,9	43,7	37,3	52,8	24,3	34,3	26,5	37,5
SHF-35A-67	SHF-50012	30,9	43,7	37,3	52,8	24,3	34,3	26,5	37,5
SHF-35A-69	SHF-50013	30,9	43,7	37,3	52,8	24,3	34,3	26,5	37,5
SHF-35A-79	SHF-50014	30,9	43,7	37,3	52,8	24,3	34,3	26,5	37,5
SHF-35B-67-02	SHF-50015	32,6	46,2	39,4	55,7	25,6	36,2	28,0	39,6
SHF-50-911D2	SHF-50016	41,2	58,3	49,8	70,4	32,3	45,7	35,3	50,0
SHF(L)-70-810	SHF-50017	63,6	89,9	76,7	108,5	49,9	70,5	54,5	77,0
SHF(L)-70-810-01	SHF-50024	63,6	89,9	76,7	108,5	49,9	70,5	54,5	77,0
SHF(L)-100-1012	SHF-50018	90,3	127,7	109,0	154,1	70,8	100,2	77,4	109,4
SHF(L)-100-1012-01	SHF-50025	90,3	127,7	109,0	154,1	70,8	100,2	77,4	109,4
SHF(L)-140-1214	SHF-50019	130,0	183,8	156,9	221,9	102,0	144,2	111,4	157,5
SHF(L)-175-1217	SHF-50020	157,1	222,2	189,7	268,2	123,2	174,3	134,6	190,4
SHF(L)-210-1321	SHF-50021	188,0	265,9	227,0	321,0	147,5	208,6	161,1	227,8
SHF(L)-350-1721	SHF-50022	308,3	436,0	372,2	526,3	241,8	342,0	264,1	373,5
SHF(L)-420-2125	SHF-50023	394,4	557,7	476,1	673,3	309,4	437,5	337,9	477,9

Note: 1) Pressure drop is valid for flow from ØC to ØS or from ØE to ØS
 2) R407C data based on dew point conditions

SHF SERIES

4 Way Reversing Valve

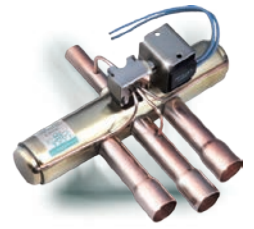

CAPACITY SELECTION

Valve Model ¹⁾	Part Number	Nominal Capacity (condition 2)							
		R407C ²⁾		R410A		R134a		R404A / R507	
		$\Delta P:$ 0,1 bar	$\Delta P:$ 0,2 bar	$\Delta P:$ 0,1 bar	$\Delta P:$ 0,2 bar	$\Delta P:$ 0,1 bar	$\Delta P:$ 0,2 bar	$\Delta P:$ 0,1 bar	$\Delta P:$ 0,2 bar
		[kW]	[kW]	[kW]	[kW]	[kW]	[kW]	[kW]	[kW]
SHF(L)-4H-23U	SHF-19001	3,4	4,8	4,0	5,7	2,7	3,9	2,7	3,9
SHF(L)-7H-34U	SHF-19002	6,4	9,0	7,5	10,6	5,1	7,2	5,1	7,2
SHF(L)-9H-35U	SHF-19003	7,3	10,3	8,5	12,0	5,8	8,2	5,8	8,2
SHF(L)-11H-45D1	SHF-19004	9,2	13,0	10,8	15,2	7,4	10,4	7,3	10,4
SHF-14-46	SHF-50001	12,7	17,9	14,8	21,0	10,1	14,3	10,1	14,3
SHF-14-47	SHF-50002	12,7	17,9	14,8	21,0	10,1	14,3	10,1	14,3
SHF-14-57	SHF-50003	12,7	17,9	14,8	21,0	10,1	14,3	10,1	14,3
SHF-20A-46	SHF-50004	16,0	22,6	18,7	26,5	12,8	18,0	12,7	18,0
SHF-20A-47	SHF-50005	16,0	22,6	18,7	26,5	12,8	18,0	12,7	18,0
SHF-20A-57	SHF-50006	16,0	22,6	18,7	26,5	12,8	18,0	12,7	18,0
SHF-20A-67	SHF-50007	16,0	22,6	18,7	26,5	12,8	18,0	12,7	18,0
SHF-20D-46-02	SHF-50008	20,2	28,5	23,6	33,4	16,1	22,8	16,1	22,7
SHF-35A-47	SHF-50009	28,2	39,8	33,0	46,6	22,5	31,8	22,4	31,7
SHF-35A-57	SHF-50010	28,2	39,8	33,0	46,6	22,5	31,8	22,4	31,7
SHF-35A-59	SHF-50011	28,2	39,8	33,0	46,6	22,5	31,8	22,4	31,7
SHF-35A-67	SHF-50012	28,2	39,8	33,0	46,6	22,5	31,8	22,4	31,7
SHF-35A-69	SHF-50013	28,2	39,8	33,0	46,6	22,5	31,8	22,4	31,7
SHF-35A-79	SHF-50014	28,2	39,8	33,0	46,6	22,5	31,8	22,4	31,7
SHF-35B-67-02	SHF-50015	29,7	42,0	34,8	49,2	23,7	33,5	23,7	33,5
SHF-50-911D2	SHF-50016	37,5	53,1	43,9	62,1	30,0	42,4	29,9	42,3
SHF(L)-70-810	SHF-50017	57,9	81,9	67,7	95,8	46,2	65,3	46,1	65,2
SHF(L)-70-810-01	SHF-50024	57,9	81,9	67,7	95,8	46,2	65,3	46,1	65,2
SHF(L)-100-1012	SHF-50018	82,2	116,3	96,2	136,1	65,6	92,8	65,5	92,7
SHF(L)-100-1012-01	SHF-50025	82,2	116,3	96,2	136,1	65,6	92,8	65,5	92,7
SHF(L)-140-1214	SHF-50019	118,4	167,4	138,5	195,9	94,5	133,6	94,3	133,4
SHF(L)-175-1217	SHF-50020	143,1	202,3	167,4	236,7	114,2	161,5	114,0	161,2
SHF(L)-210-1321	SHF-50021	171,2	242,1	200,3	283,3	136,6	193,2	136,5	193,0
SHF(L)-350-1721	SHF-50022	280,7	397,0	328,5	464,6	224,0	316,8	223,7	316,4
SHF(L)-420-2125	SHF-50023	359,1	507,9	420,2	594,3	286,6	405,3	286,2	404,8

Note: 1) Pressure drop is valid for flow from ØC to ØS or from ØE to ØS
 2) R407C data based on dew point conditions

SHF SERIES

4 Way Reversing Valve

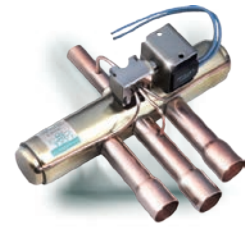

DIMENSIONS - VALVES

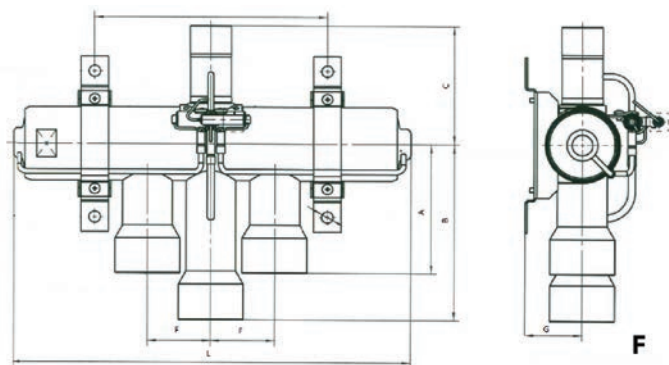
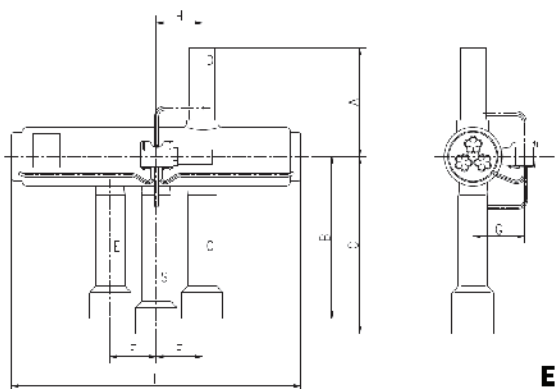
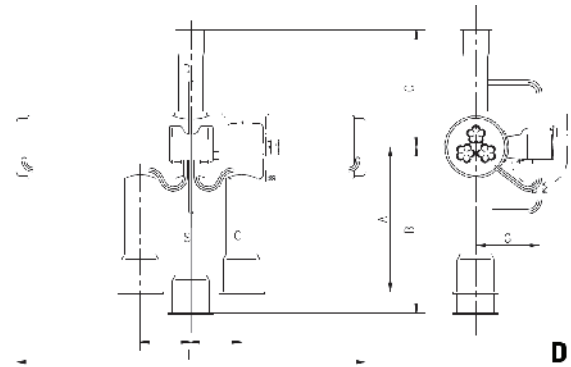
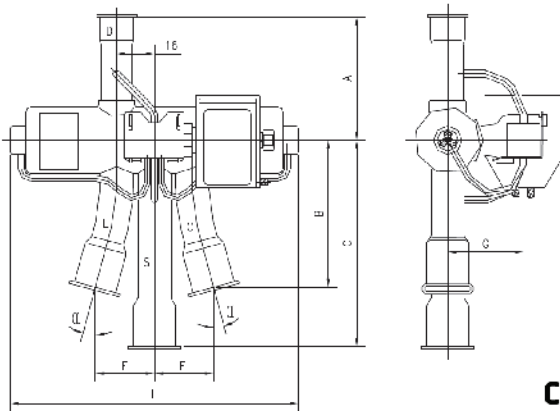
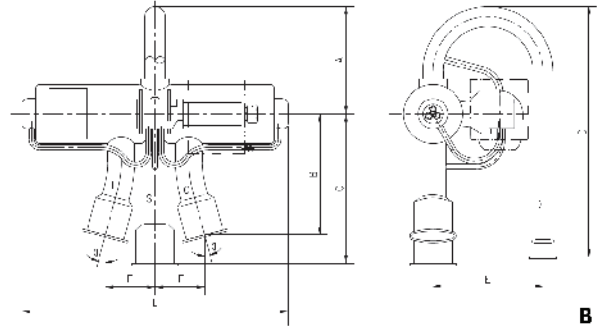
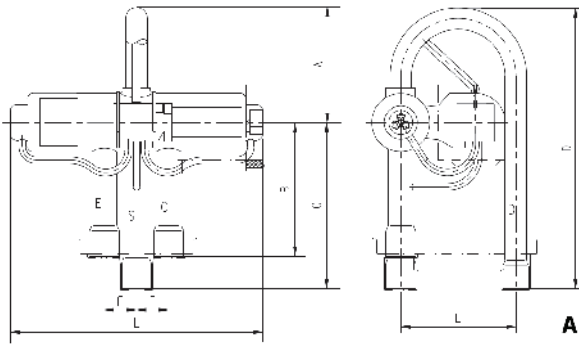

SHF SERIES

4 Way Reversing Valve

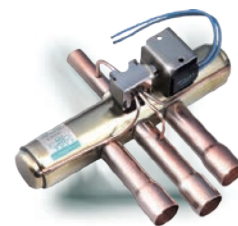

DIMENSIONS - VALVES

Valve Model	Part Number	Valve Style	L	A	B	C	D	E	F	G	H	Angle α	Weight
			[mm]	[mm]	[mm]	[mm]	[mm]	[mm]	[mm]	[mm]	[mm]	[mm]	[°]
SHF(L)-4H-23U	SHF-19001	A	94,4	43	50	62	105	43	12	-	-	0	0,20
SHF(L)-7H-34U	SHF-19002		113	51	59	71	119	52	16	-	-	0	0,28
SHF(L)-9H-35U	SHF-19003	B	115,5	51	57	72	119	52	23,5	-	-	15	0,30
SHF(L)-11H-45D1	SHF-19004	C	121,5	52	62	87	-	-	25	31,5	16	15	0,32
SHF-14-46	SHF-50001	D	184,2	67	83	95	-	-	28,6	35,5	-	0	0,72
SHF-14-47	SHF-50002		184,2	67	83	95	-	-	28,6	35,5	-	0	0,72
SHF-14-57	SHF-50003		184,2	67	83	95	-	-	28,6	35,5	-	0	0,72
SHF-20A-46	SHF-50004		176	67	83	95	-	-	28,6	35,5	-	0	0,75
SHF-20A-47	SHF-50005		176	67	83	95	-	-	28,6	35,5	-	0	0,75
SHF-20A-57	SHF-50006		176	67	83	95	-	-	28,6	35,5	-	0	0,75
SHF-20A-67	SHF-50007		176	67	83	95	-	-	28,6	35,5	-	0	0,75
SHF-20D-46-02	SHF-50008		183,6	67	83	95	-	-	28,6	35,5	-	0	0,75
SHF-35A-47	SHF-50009		211	82	87	100	-	-	33	40	-	0	1,30
SHF-35A-57	SHF-50010		211	82	87	100	-	-	33	40	-	0	1,30
SHF-35A-59	SHF-50011		211	82	87	100	-	-	33	40	-	0	1,30
SHF-35A-67	SHF-50012		211	82	87	100	-	-	33	40	-	0	1,30
SHF-35A-69	SHF-50013		211	82	87	100	-	-	33	40	-	0	1,30
SHF-35A-79	SHF-50014		211	82	87	100	-	-	33	40	-	0	1,30
SHF-35B-67-02	SHF-50015		213	82	87	100	-	-	33	40	-	0	1,30
SHF-50-911D2	SHF-50016		E	269	97	149	174	-	-	41,3	40	41,3	0
SHF(L)-70-810	SHF-50017	D	303	111,8	117	131	-	-	46	86	-	0	3,00
SHF(L)-100-1012	SHF-50018		321	111,8	117	131	-	-	49	86	-	0	3,50
SHF(L)-70-810-01	SHF-50024	F	303	111,8	117	131	-	-	46	86	-	0	3,00
SHF(L)-100-1012-01	SHF-50025		321	111,8	117	131	-	-	49	86	-	0	3,50
SHF(L)-140-1214	SHF-50019		390	135,6	148,7	168,7	-	-	58	97	-	0	7,20
SHF(L)-175-1217	SHF-50020		390	135,6	148,7	168,7	-	-	58	97	-	0	7,60
SHF(L)-210-1321	SHF-50021		452	135,6	148,7	168,7	-	-	71,5	97	-	0	8,70
SHF(L)-350-1721	SHF-50022		553	176,5	180	235	-	-	75	112	-	0	22,00
SHF(L)-420-2125	SHF-50023	613	176,5	180	235	-	-	93	113	-	0	26,00	

SHF SERIES

4 Way Reversing Valve



COIL CHARACTERISTICS

Coil Model ¹⁾	Winding Code	Part Number	Electrical function / connection Type	Cable Length	Power Supply	Rated Voltage	Power Consumption			Protection class	Insulation class	Max. Op. Temp.
							AC 50Hz	AC 60Hz	DC			
				[mm]	[-]	[V]	[W]	[W]	[W]	[-]	[-]	[°C]
SQ-A25 22G-00 0001	SHF-4-10L3	SHF-56001	Lead Wires	500	AC	220-240	4,5	3,5	-	IP54	B ²⁾	130
SQ-A25 200-00 0001	SHF-4-10L2	SHF-56002	Lead Wires	500	AC	200	4,5	3,5	-			
SQ-A25 100-00 0001	SHF-4-10L1	SHF-56003	Lead Wires	500	AC	100	4,5	3,5	-			
SQ-A25 11A-00 0001	SHF-4-10L4	SHF-56004	Lead Wires	500	AC	110-120	4,5	3,5	-			
SQ-A25 024-00 0001	SHF-4-10L5	SHF-56005	Lead Wires	500	AC	24	4,5	3,5	-			
SQ-A25 26H-00 0001	SHF-4-10L6	SHF-56006	Lead Wires	500	AC	265-277	4,5	3,5	-			
SQ-A25 22G-00 0870	SHF-4-10L3	SHF-56024	Lead Wires	1500	AC	220-240	4,5	3,5	-	IP00	F ³⁾	155
SQ-A25 11A-00 0840	SHF-4-10L4	SHF-56025	Lead Wires	1500	AC	110-120	4,5	3,5	-			
SQ-A25 024-00 0161	SHF-4-10L5	SHF-56009	Lead Wires	1500	AC	24	4,5	3,5	-			
SQ-A44 22G-00 0771	SHF-4-10FA5	SHF-56012	Spade (Faston) ⁴⁾	-	AC	220-240	6	5	-			
SQ-A44 220-00 0001	SHF-4-10FA1	SHF-56013	Spade (Faston) ⁴⁾	-	AC	220	6	5	-			
SQ-A44 11B-00 0001	SHF-4-10FA2	SHF-56014	Spade (Faston) ⁴⁾	-	AC	120	6	5	-			
SQ-A44 10A-00 0001	SHF-4-10FA3	SHF-56015	Spade (Faston) ⁴⁾	-	AC	100-110	6	5	-	IP54	B ²⁾	130
SQ-A44 024-00 0771	SHF-4-10FA4	SHF-56016	Spade (Faston) ⁴⁾	-	AC	24	6	5	-			
SQ-A44 26H-00 0831	SHF-4-10FA6	SHF-56017	Spade (Faston) ⁴⁾	-	AC	265-277	6	5	-			
SQ-D44 012-00 0001	SHF-4-10FA8	SHF-56019	Spade (Faston) ⁴⁾	-	DC	12	-	-	10			
SQ-D44 024-00 0001	SHF-4-10FA9	SHF-56020	Spade (Faston) ⁴⁾	-	DC	24	-	-	11			
SQ-A27 100-00 0001	-	SHF-56021	Bistable/ Lead W.	500	AC	100	18	18	-			
SQ-A27 200-00 0001	-	SHF-56022	Bistable/ Lead W.	500	AC	200	18	18	-	IP54	B ²⁾	130
SQ-A27 20K-00 0001	-	SHF-56027	Bistable/ Lead W.	500	AC	220-240	18	18	-			
SQ-D27 012-00 0001	-	SHF-56023	Bistable/ Lead W.	500	DC	12	-	-	20			

- Note:**
- 1) Every coil is applicable to all above specified valve models
 - 2) Max ambient temperature up to + 50°C
 - 3) Max ambient temperature up to + 70°C
 - 4) Wire Harness for coil with Faston connector:
SQ-000000-090028 (Part Number: SHF-56026)

SHF SERIES

4 Way Reversing Valve



DIMENSIONS - COILS

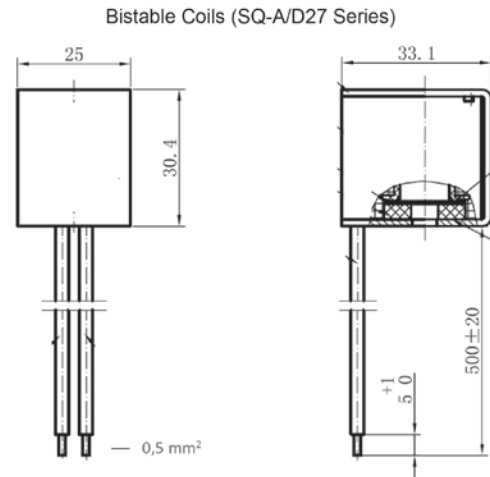
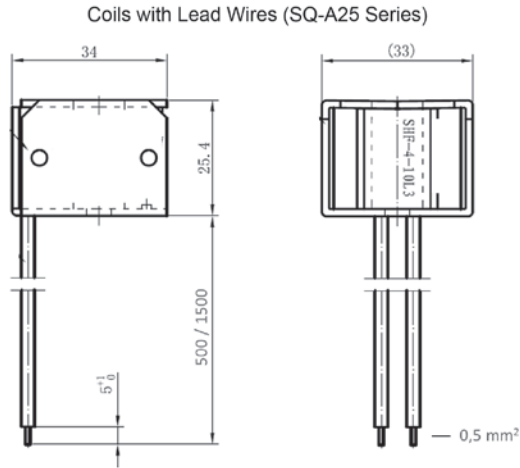

Coils with Spade Connections (SQ-A/D44 Series)

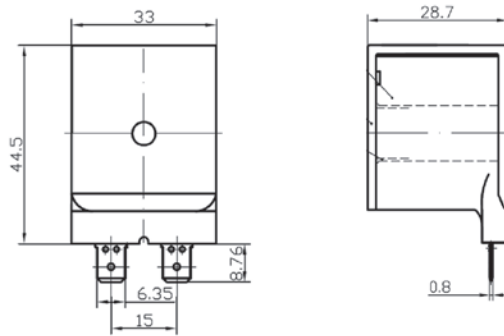

Wire Harness (SQ-000000-090028)

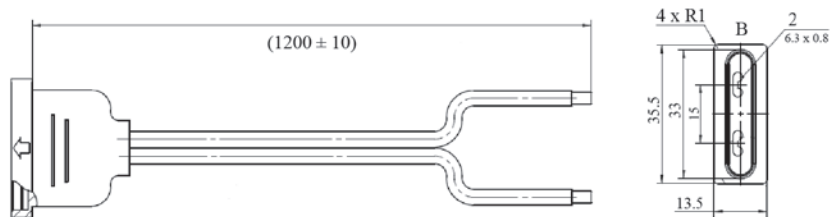

4 Way Reversing Valve

SHF (HP) series four-way reversing valves are designed especially for usage in heat pump systems to realize switching between cooling mode and heating mode by changing the flow path of the refrigerant.

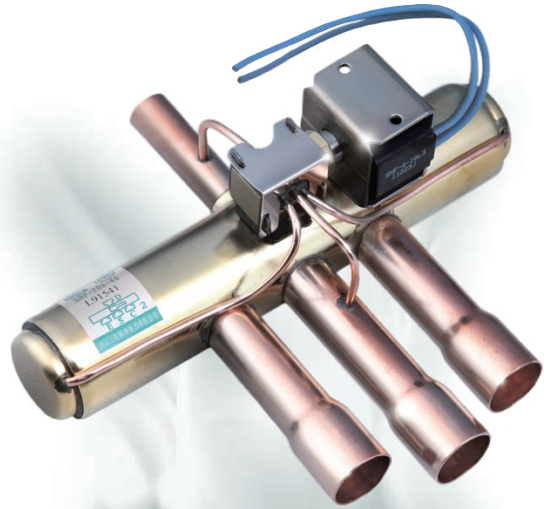

FEATURES

- WIDE APPLICATION RANGE
- SUITABLE FOR COOLING CAPACITIES FROM 3 TO 40 KW (R407C, CONDITION 1)
- SEVERAL DESIGNS AVAILABLE

GENERAL SPECIFICATIONS

- Applicable for all common HCFC and HFC refrigerants such as: R22, R134a, R404A, R407C, R410A, R507A ...
- Medium temperature TS min./max.: -30°C / +135°C
- Ambient temperature min./max.: -25°C / +70°C
- Relative humidity: 0 to 95% RH
- Max. operating pressure PS: 4,5 MPa (45 bar)

- Max. opening pressure difference OPD: 4,0 MPa (40 bar)
- Installation position:
 - Coil upwards or with body axis in horizontal alignment
 - Flow direction according to installation instruction
- Certifications: UL/CSA* and declaration according to LVD or PED

* Coil selection on request

NOMINAL OPERATING CONDITIONS

Nominal operating conditions	Condition 1:	Condition 2:
Condensing Temperature t_c	38°C	54,4°C
Evaporating Temperature t_o	5°C	7,2°C
Superheat Δt_{oh}	5K	5K
Subcooling Δt_{cu}	0K	5K

SHF (HP) SERIES

4 Way Reversing Valve

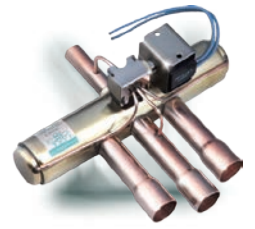

GENERAL CHARACTERISTICS

Valve Model	Part Number	Ø Port [mm]	Kv [m ³ /h]	Connections ODF		MOP [MPa]	OPD		PED category
				ØD	ØE/S/C		MAX	MIN	
				[inch]	[inch]		[MPa]	[MPa]	
SHF(L)-4H-23U-E	SHF-19005	8,0	1,7	5/16	3/8	4,5	4,0	0,25	3,3
SHF(L)-7H-34U-E	SHF-19006	11,1	3,1	3/8	1/2	4,5	4,0	0,25	3,3
SHF-20D-46-02-E	SHF-50022	17,2	9,9	1/2	3/4	4,5	4,0	0,34	I
SHF-35B-67-02-E	SHF-50023	20,9	14,7	3/4	7/8	4,5	4,0	0,34	I

CAPACITY SELECTION

Valve Model ¹⁾	Part Number	Nominal Capacity (condition 1)							
		R407C ²⁾		R410A		R134a		R404A / R507	
		ΔP: 0,1 bar	ΔP: 0,2 bar	ΔP: 0,1 bar	ΔP: 0,2 bar	ΔP: 0,1 bar	ΔP: 0,2 bar	ΔP: 0,1 bar	ΔP: 0,2 bar
		[kW]	[kW]	[kW]	[kW]	[kW]	[kW]	[kW]	[kW]
SHF(L)-4H-23U-E	SHF-19005	3,8	5,3	4,5	6,4	2,9	4,2	3,2	4,6
SHF(L)-7H-34U-E	SHF-19006	7,0	9,9	8,5	12,0	5,5	7,8	6,0	8,5
SHF-20D-46-02-E	SHF-50022	22,1	31,3	26,7	37,8	17,4	24,6	19,0	26,8
SHF-35B-67-02-E	SHF-50023	32,6	46,2	39,4	55,7	25,6	36,2	28,0	39,6
Valve Model ¹⁾	Part Number	Nominal Capacity (condition 2)							
		R407C ²⁾		R410A		R134a		R404A / R507	
		ΔP: 0,1 bar	ΔP: 0,2 bar	ΔP: 0,1 bar	ΔP: 0,2 bar	ΔP: 0,1 bar	ΔP: 0,2 bar	ΔP: 0,1 bar	ΔP: 0,2 bar
		[kW]	[kW]	[kW]	[kW]	[kW]	[kW]	[kW]	[kW]
SHF(L)-4H-23U-E	SHF-19005	3,4	4,8	4,0	5,7	2,7	3,9	2,7	3,9
SHF(L)-7H-34U-E	SHF-19006	6,4	9,0	7,5	10,6	5,1	7,2	5,1	7,2
SHF-20D-46-02-E	SHF-50022	20,2	28,5	23,6	33,4	16,1	22,8	16,1	22,7
SHF-35B-67-02-E	SHF-50023	29,7	42,0	34,8	49,2	23,7	33,5	23,7	33,5

Note: 1) Pressure drop is valid for flow from ØC to ØS or ØE to ØS
 2) R407C data based on dew point conditions

SHF (HP) SERIES 4 Way Reversing Valve

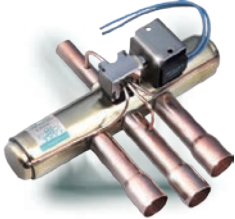

DIMENSIONS - VALVES

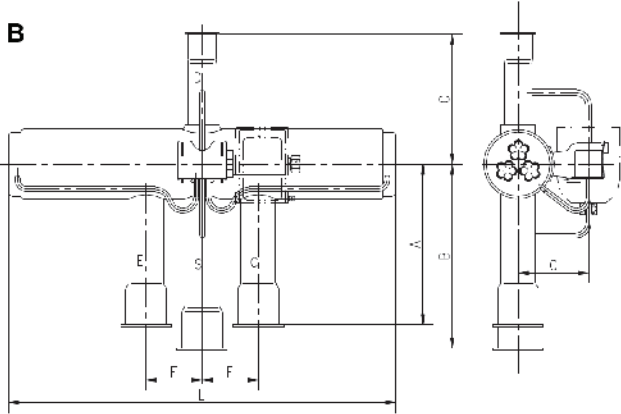
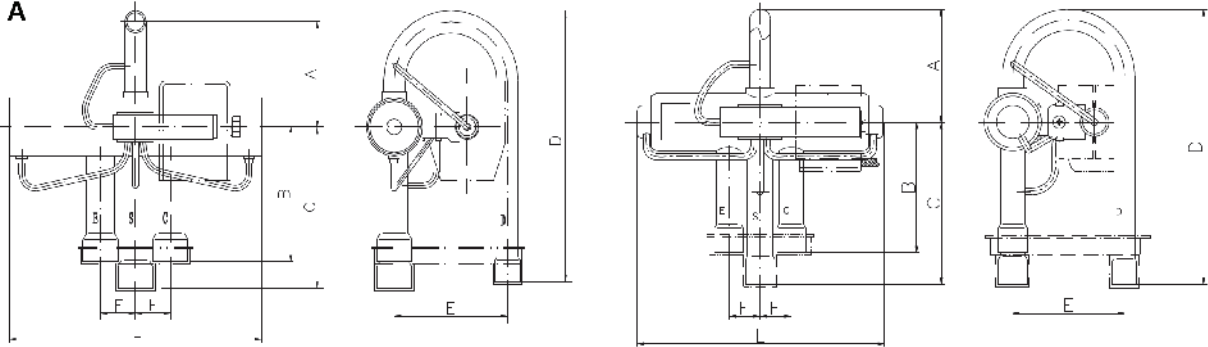

Valve Model	Part Number	Valve Style	L	A	B	C	D	E	F	G	Weight
			[mm]	[mm]	[mm]	[mm]	[mm]	[mm]	[mm]	[mm]	[kg]
SHF(L)-4H-23U-E	SHF-19005	A	94,4	43	50	62	105	43	12	-	0,20
SHF(L)-7H-34U-E	SHF-19006		113	51	59	71	119	52	16	-	0,28
SHF-20D-46-02-E	SHF-50022	B	183,6	67	83	95	-	-	28,6	35,5	0,75
SHF-35B-67-02-E	SHF-50023		213	82	87	100	-	-	33	40	1,23

SHF (HP) SERIES 4 Way Reversing Valve

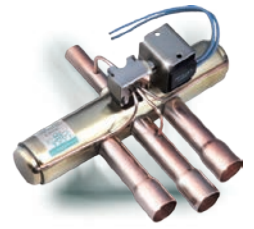

COIL CHARACTERISTICS

Coil Model ¹⁾	Winding Code	Part Number	Electrical Connection Type	Power Supply	Rated Voltage	Power Consumption			Protection class	Insulation class	Max Operating Temp.
						AC 50Hz	AC 60Hz	DC			
				[-]	[V]	[W]	[W]	[W]	[-]	[-]	[°C]
SQ-A44 22G-00 0771	SHF-4-10FA5	SHF-56012	Spade (Faston)	AC	220 to 240	6	5	-	IP00	F	155
SQ-A44 220-00 0001	SHF-4-10FA1	SHF-56013	Spade (Faston)	AC	220	6	5	-	IP00	F	155
SQ-A44 11B-00 0001	SHF-4-10FA2	SHF-56014	Spade (Faston)	AC	120	6	5	-	IP00	F	155
SQ-A44 10A-00 0001	SHF-4-10FA3	SHF-56015	Spade (Faston)	AC	100 to 110	6	5	-	IP00	F	155
SQ-A44 024-00 0771	SHF-4-10FA4	SHF-56016	Spade (Faston)	AC	24	6	5	-	IP00	F	155
SQ-A44 26H-00 0831	SHF-4-10FA6	SHF-56017	Spade (Faston)	AC	265 to 277	6	5	-	IP00	F	155
SQ-A44 200-00 0001	SHF-4-10FA7	SHF-56018	Spade (Faston)	AC	200	6	5	-	IP00	F	155
SQ-D44 012-00 0001	SHF-4-10FA8	SHF-56019	Spade (Faston)	DC	12	-	-	10	IP00	F	155
SQ-D44 024-00 0001	SHF-4-10FA9	SHF-56020	Spade (Faston)	DC	24	-	-	11	IP00	F	155

Note: 1) Every coil is applicable to all above specified valve models

DIMENSIONS - COIL

Coils with Spade Connections

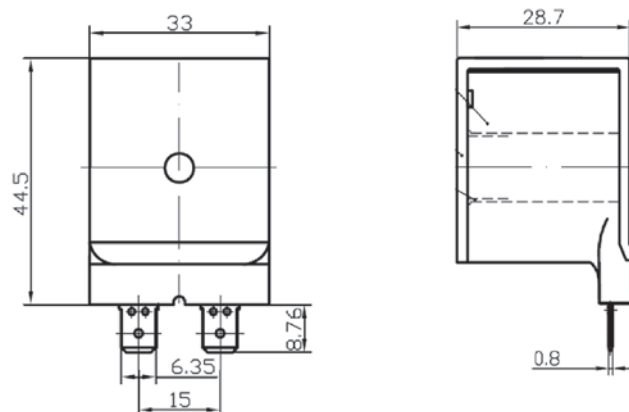

Electronic Expansion Valve

T/S series electronic expansion valves are designed for use in air conditioning and refrigeration systems or in heat pumps. The valve controls the automatic adjustment of refrigerant flow rate and makes the system work under optimized conditions for the purpose of fast cooling or heating, precise temperature control and energy saving. The valve can also be used e.g. for suction line pressure controls. These valves provide bidirectional operation to control the refrigerant flow rate in heating or cooling mode.

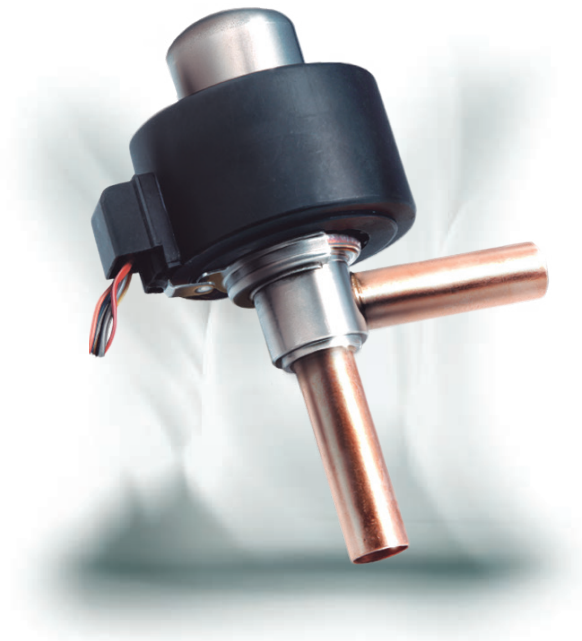

FEATURES

- APPLICABLE FOR OIL-FREE SYSTEM (T SERIES)
- SMALLER INSTALLATION SPACE: LOW HEIGHT, SMALL VOLUME, LIGHT WEIGHT
- OPTIMIZED FLOW PATH DESIGN FOR NOISE REDUCTION
- FAST OPERATION, ENERGY SAVING
- APPLICABLE FOR REVERSIBLE SYSTEMS LIKE HEAT PUMPS: BIDIRECTIONAL FLOW

GENERAL SPECIFICATIONS

- Applicable for all common HCFC and HFC refrigerants such as: R22, R134a, R404A, R407C, R410A, R507A ...
- Cooling capacity: 3,5 to 105 kW (R22 nominal capacity)
- 500 steps (full stroke); 32 ± 20 opening steps
- Medium temperature TS min./max.: -30°C / +70°C (duty cycle rate below 50%)
- Ambient temperature min./max.: -30°C / +60°C (duty cycle rate below 50%)
- Relative humidity: : 0 to 95% RH
- Installation position: :
 - Coil installed in the upwards position, valve rotor central axis within ±15° versus vertical axis
 - Inlet connection preferably sidewise, outlet preferably downwards
- Certifications: UL/CSA and declaration according to LVD or PED

DPF-T/S SERIES

Electronic Expansion Valve



ELECTRICAL PARAMETERS

- Rated voltage: 12V DC(± 10%), rectangular wave
- Actuating mode: 4-phase 8-step permanent magnet stepping motor of direct-acting type
- Excitation mode: 1 ~ 2 phase excitation, monopole actuation
- Excitation rate:
 - Seat Ø 1,3 to 3,2 mm: 30 to 90pps
 - Seat Ø 4,0 to 6,5 mm: 30 to 40pps
- Activation of self-holding mechanism: Maintain excitation in stop position min. 0,1~1,0 sec.
- Min. motion time from completely open to completely closed:
 - Seat Ø 1,3 to 3,2 mm: 6s @ 90pps
 - Seat Ø 4,0 to 6,5 mm: 13s @ 40pps
- Coil current:
 - Seat Ø 1,3 to 3,2 mm: 260mA/phase (20°C)
 - Seat Ø 4,0 to 6,5 mm: 375mA/phase (20°C)
- Coil resistance:
 - Seat Ø 1,3 to 3,2 mm: 46 ± 3.7 Ω/phase (20°C)
 - Seat Ø 4,0 to 6,5 mm: 32 ± 3.2 Ω/phase (20°C)
- Insulation class of coil: E
- Protection class: IP 66

GENERAL CHARACTERISTICS

Valve Model	Part Number ¹⁾	Seat ϕ (mm)	Kv (m ³ /h)	Nominal Cooling Capacity ²⁾ [kW]					MOP Max. Oper. Press. [MPa]	MOPD Direct [MPa]	MOPD Rev. (MPa)
				R22	R134a	R407C ³⁾	R404A R507A	R410A			
DPF(T01)1.3C-07	DPF-09001	1,3	0,05	3,5	2,7	3,5	2,5	4,2	4,5	3,5	≥2.1
DPF(T01)1.65C-05	DPF-09002	1,65	0,08	5,3	4,1	5,3	3,7	6,36			
DPF(T01)1.8C-08	DPF-09003	1,8	0,1	7	5,4	7	4,9	8,4			
DPF(T01)2.0C-03	DPF-09004	2	0,16	8,8	6,7	8,75	6,1	10,5			
DPF(T01)2.2C-01	DPF-09005	2,2	0,2	11	8,1	10,5	7,4	12,6			
DPF(T01)2.4C-01	DPF-09006	2,4	0,23	18	13,5	17,5	12,3	21			
DPF(TS1)3.0C-01	DPF-09007	3	0,39	21	16,2	21	14,7	25,2			≥1.47
DPF(TS1)3.2C-01	DPF-09008	3,2	0,43	28	21,6	28	19,6	33,6			
DPF(S03)4.0C-01	DPF-09010	4	0,5	42	32,3	42	29,4	50,4			≥0.7
DPF(S03)4.5C-01	DPF-09011	4,5	0,7	53	40,4	52,5	36,8	63			
DPF(S03)5.5C-01	DPF-09012	5,5	0,9	70	53,9	70	49,0	84			
DPF(S03)6.5C-02	DPF-09013	6,5	1,1	105	80,9	105	73,5	126			

- Note:**
- 1) Extent of delivery without coil
 - 2) Nominal working conditions: Condensing Temperature 38°C; Evaporating Temperature 5°C; Sub-cooling 0K; Superheat 0K
 - 3) R407C data based on dew point conditions

DPF-T/S SERIES

Electronic Expansion Valve



FLOW CHARACTERISTIC

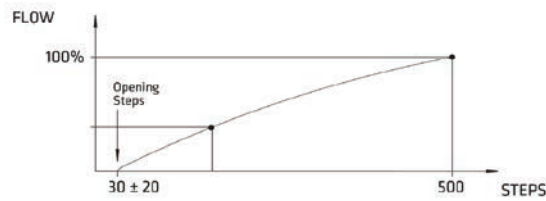

DIMENSIONS

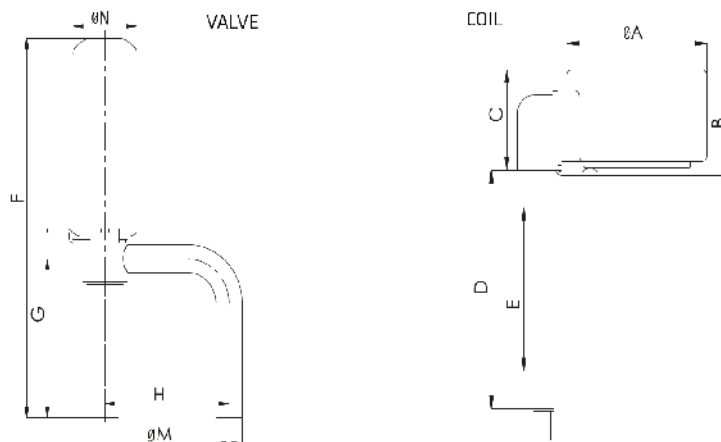

Valve Model	Coil Series	Valve Dimensions [mm]				
		F	G	H	Ød	ØN
DPF(T01)1.3C-07 to DPF(T01)2.4C-01	PQ-M10	78	36	30	6,35	17,3
DPF(TS1)3.0C-01 to DPF(TS1)3.2C-01		82	40	30	7,94	17,3
DPF(S03)4.0C-01 to DPF(S03)6.5C-02	PQ-M03	148	64,7	63,4	15,88	35,3

Valve Model	Coil Model	Coil Dimensions [mm]					Coil Part Number
		ØA	B	C	D	E	
DPF(T01)1.3C-07 to DPF(TS1)3.2C-01	PQ-M10 012-000001	38,5	26,4	25,6	700	600	DPF-58001
DPF(S03)4.0C-01 to DPF(S03)6.5C-02	PQ-M03 012-000001	67,5	42,4	33	700	600	DPF-58002

Every 4th car is equipped
with a **SANHUA**
expansion valve

YEARLY SANHUA SUPPLIES OVER
40 MILLION THERMOSTATIC AND
ELECTRONIC EXPANSION VALVES
TO THE HVAC & AUTOMOTIVE
INDUSTRIES WORLDWIDE

DISCOVER
WHY

www.sanhuaeurope.com

- ✓ Improves HVAC&R system efficiency up to **20%**
- ✓ DPF&VPF series from 2kW to 1400kW
*75kW and 1400kW available in Quarter 4
- ✓ Advanced MSS (Minimum Stable Superheat) control logic



 **SANHUA**

CHILLING *IDEAS* WORLDWIDE

SANHUA INTERNATIONAL EUROPE
info@sanhuaeurope.com

Solenoid Valve

MDF series solenoid valves are direct operated or pilot operated solenoid valves, mainly used in refrigerant control of various devices such as refrigerating and freezing systems, air conditioners and heat pumps.

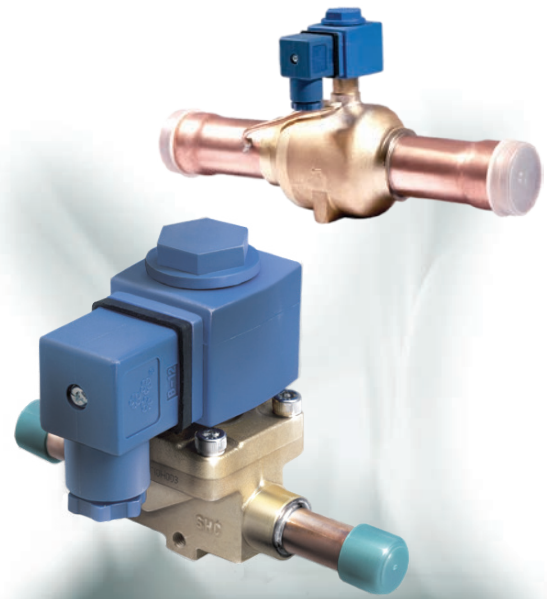

FEATURES

- COILS: LOW ENERGY CONSUMPTION, RELIABLE
- GREAT VALVE OPENING PERFORMANCE, HIGH MOPD
- COILS ARE DOUBLE SEALED, WATER TIGHT AND SAFE

GENERAL SPECIFICATIONS

- Applicable for all common HCFC and HFC refrigerants such as: R22, R134a, R407C, R404A, R410A, R507A
- Medium temperature TS min./max.:
 - MDF 2H...22H and MDF 2L...15L: -30°C/105°C
 - MDF 25H...40H: -40°C/140°C
- Ambient temperature min./max.: -30°C / +55°C
- Relative humidity: 0 to 95% RH
- Installation position:
 - Liquid, suction and discharge line
 - Preferably coil upwards and flow direction corresponds to the arrow
- Declaration according to LVD or PED

TECHNICAL PARAMETERS

Technical parameters of Coil

Model Coil ¹⁾	Rated Voltage [V]	Supply	Power [W]	Part Number	Frequ. [Hz]	Voltage Tolerance	Insulation Class	Protection Class (w/plug)	Wiring type
MQ-A03024-000001	24	AC	10,5W (50Hz) 8,5W (60Hz)	MDF-60001	50/60	-15% +10%	F	IP65	DIN Plug
MQ-A0311A-000001	110 to 120		12W (50Hz) 10W (60Hz)	MDF-60002					
MQ-A0322G-000001	220 to 240		12W (50Hz) 10W (60Hz)	MDF-60003					
MQ-D03024-000002	24	DC	12W (50Hz) 10W (60Hz)	MDF-60004	-	±10%			

Note: 1) Applicable to MDF-A03 and MDF-B03 valve bodies

MDF SERIES

Solenoid Valve

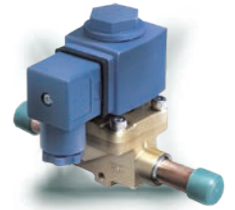

Technical Parameters of Valve Body

Solder	Flare	Normal position	Actuation	Kv [m ³ /h]	MOP [Mpa]	Max. OPD [Mpa]	Min. OPD [Mpa]		
MDF-A03-2H	MDF-A03-2L	NC	Direct	0,16	4,5	3,1	0,00		
MDF-A03-3H	MDF-A03-3L			0,23					
MDF-A03-6H	MDF-A03-6L			0,8					
MDF-A03-10H	MDF-A03-10L			1,9					
MDF-A03-15H	MDF-A03-15L			2,3					
MDF-A03-20H	--		Pilot ¹⁾	5,0			0,02		
MDF-A03-22H	--			5,9					
MDF-B03-25H	--			10,0					
MDF-B03-32H	--			Pilot (P) ²⁾				15,0	0,03
MDF-B03-40H	--							25,0	

Note: 1) Membrane operated
2) Piston operated

DIMENSIONS

Valve Body
Thread Connection

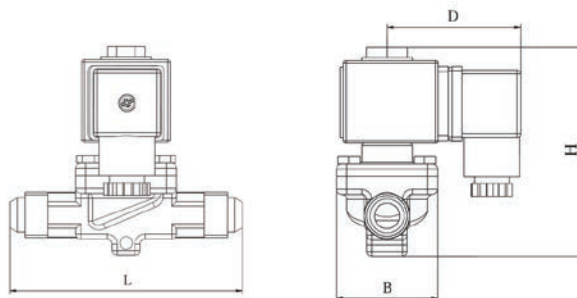

Model Valve Body	SAE Flare Connection [inch]	Part Number ¹⁾	PED Category	Dimensions [mm]			
				L	B	D	H
MDF-A03-2L 001	1/4	MDF-08039	3.3	59	30	53	82
MDF-A03-3L 001	1/4	MDF-08040	3.3	59	30	53	82
MDF-A03-3L 003	3/8	MDF-08041	3.3	59	30	53	82
MDF-A03-6L 001	3/8	MDF-08042	3.3	69	36	53	88
MDF-A03-6L 003	1/2	MDF-08043	3.3	69	36	53	88
MDF-A03-10L 003	1/2	MDF-08044	3.3	92	42	53	96
MDF-A03-10L 001	5/8	MDF-08045	3.3	92	42	53	96
MDF-A03-15L 001	5/8	MDF-08046	3.3	104	52	53	100
MDF-A03-15L 003	7/8	MDF-08047	3.3	104	52	53	100

Note: 1) Extent of delivery: valve body without coil

MDF SERIES

Solenoid Valve

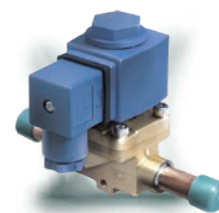

DIMENSIONS

Valve Body Solder Connection [inch]

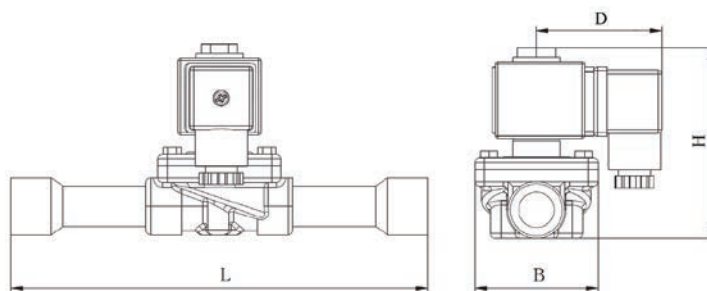

Model Valve Body	Solder Connection [inch]	Part Number ¹⁾	PED Category	Dimensions [mm]			
				L	B	D	H
MDF-A03-2H 001	1/4	MDF-08001	3.3	102	30	53	82
MDF-A03-3H 001	1/4	MDF-08002	3.3	102	30	53	82
MDF-A03-3H 003	3/8	MDF-08003	3.3	102	30	53	82
MDF-A03-6H 001	3/8	MDF-08004	3.3	111	36	53	88
MDF-A03-6H 003	1/2	MDF-08005	3.3	111	36	53	88
MDF-A03-10H 001	1/2	MDF-08006	3.3	127	42	53	95
MDF-A03-10H 003	5/8	MDF-08007	3.3	127	42	53	95
MDF-A03-15H 001	5/8	MDF-08008	3.3	176	52	53	100
MDF-A03-15H 003	7/8	MDF-08009	3.3	176	52	53	100
MDF-A03-20H 001	7/8	MDF-08010	3.3	191	52	53	117
MDF-A03-20H 003	1-1/8	MDF-08011	3.3	191	52	53	117
MDF-A03-22H 001	7/8	MDF-08012	3.3	191	60	53	117
MDF-A03-22H 009	1-1/8	MDF-08048	3.3	191	60	53	117
MDF-A03-22H 003	1-3/8	MDF-08013	I	191	60	53	117
MDF-B03-25H 003	1-1/8	MDF-08014	3.3	280	76	53	144
MDF-B03-25H 004	1-3/8	MDF-08015	I	280	76	53	144
MDF-B03-32H 001	1-3/8	MDF-08016	I	281	76	53	144
MDF-B03-32H 002	1-5/8	MDF-08017	I	281	76	53	144
MDF-B03-40H 002	1-5/8	MDF-08018	I	281	84	53	152
MDF-B03-40H 004	2-1/8	MDF-08019	I	281	84	53	152

Note: 1) Extent of delivery: valve body without coil

MDF SERIES Solenoid Valve



DIMENSIONS

Valve Body Solder Connection [mm]

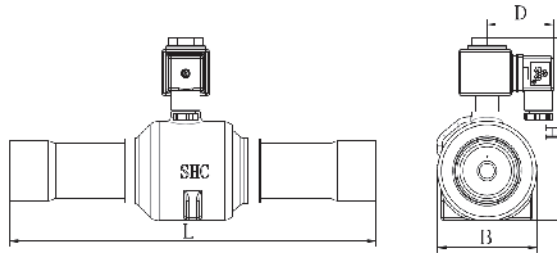

Model Valve Body	Solder Connection [mm]	Part Number ¹⁾	PED Category	Dimensions [mm]			
				L	B	D	H
MDF-A03-2H 003	6	MDF-08020	3.3	102	30	53	82
MDF-A03-3H 005	6	MDF-08021	3.3	102	30	53	82
MDF-A03-3H 007	10	MDF-08022	3.3	102	30	53	82
MDF-A03-6H 005	10	MDF-08023	3.3	111	36	53	88
MDF-A03-6H 007	12	MDF-08024	3.3	111	36	53	88
MDF-A03-10H 005	12	MDF-08025	3.3	127	42	53	95
MDF-A03-10H 003	16	MDF-08007	3.3	127	42	53	95
MDF-A03-15H 001	16	MDF-08008	3.3	176	52	53	100
MDF-A03-15H 003	22	MDF-08009	3.3	176	52	53	100
MDF-A03-20H 001	22	MDF-08010	3.3	191	52	53	117
MDF-A03-20H 007	28	MDF-08030	3.3	191	52	53	117
MDF-A03-22H 001	22	MDF-08012	3.3	191	60	53	117
MDF-A03-22H 011	28	MDF-08031	3.3	191	60	53	117
MDF-A03-22H 003	35	MDF-08013	I	191	60	53	117
MDF-B03-25H 005	28	MDF-08033	3.3	280	76	53	144
MDF-B03-25H 004	35	MDF-08015	I	280	76	53	144
MDF-B03-32H 001	35	MDF-08016	I	281	76	53	144
MDF-B03-32H 003	42	MDF-08036	I	281	76	53	144
MDF-B03-40H 003	42	MDF-08037	I	281	84	53	152
MDF-B03-40H 004	54	MDF-08019	I	281	84	53	152

Note: 1) Extent of delivery: valve body without coil

Solenoid Valve

FDF series solenoid valves are direct operated or pilot operated solenoid valves, mainly used in refrigerant control of various devices such as refrigerating and freezing systems, air conditioners and heat pumps.



FEATURES

- COILS: LOW ENERGY CONSUMPTION, RELIABLE
- GREAT VALVE OPENING PERFORMANCE, HIGH MOPD

GENERAL SPECIFICATIONS

- Applicable for all common HCFC and HFC refrigerants such as: R22, R134a, R404A, R407C, R410A, R507A ...
- Medium temperature TS min./max.: -30°C / 120°C
- Ambient temperature min./max.: -30°C / +50°C
- Relative humidity: 0 to 95% RH
- Installation position: - Liquid, suction and discharge line
- Coil upwards, coil axis $\pm 15^\circ$ tolerance versus vertical axis
- Flow direction corresponds to the arrow
- Certifications: UL/CSA* and declaration according to LVD or PED

TECNHICAL PARAMETERS OF VALVE BODY

Model Valve Body	Part Number	Normal Position	Actuation	Ø Seat	Kv	MOP	Max. OPD	Min. OPD	Ød OD	Ød OD	Measurement [mm]		
				[mm]	[m ³ /h]	[MPa]	[MPa]	[MPa]	[mm]	[inch]	L	L1	L2
FDF 2A 94	FDF-06001	NC	Direct	1,9	0,08	4,5	3,4	0	6,35	1/4	67	32	34
FDF 2.5A 08	FDF-06002			2,5	0,20		2,1	0,01	6,35	1/4	85	38	38
FDF 3A 08	FDF-06003			2,7	0,26		3,4		7,94	5/16	81	35	36
FDF 4A 10	FDF-06004			4,0	0,26		3,4		6,35	1/4	81	35	38
FDF 6A 58	FDF-06005		Pilot	5,8	0,56		3,0		7,94	5/16	81	35	36
FDF 8A 21	FDF-06006			8,0	0,95		2,8	0,02	12,7	1/2	114	62	62
FDF 11A 16	FDF-06007			11	2,40				12,7	1/2	113	61	61
FDF 13A 12	FDF-06008			13	3,44				15,88	5/8	114	62	62



DIMENSIONS - VALVE BODY

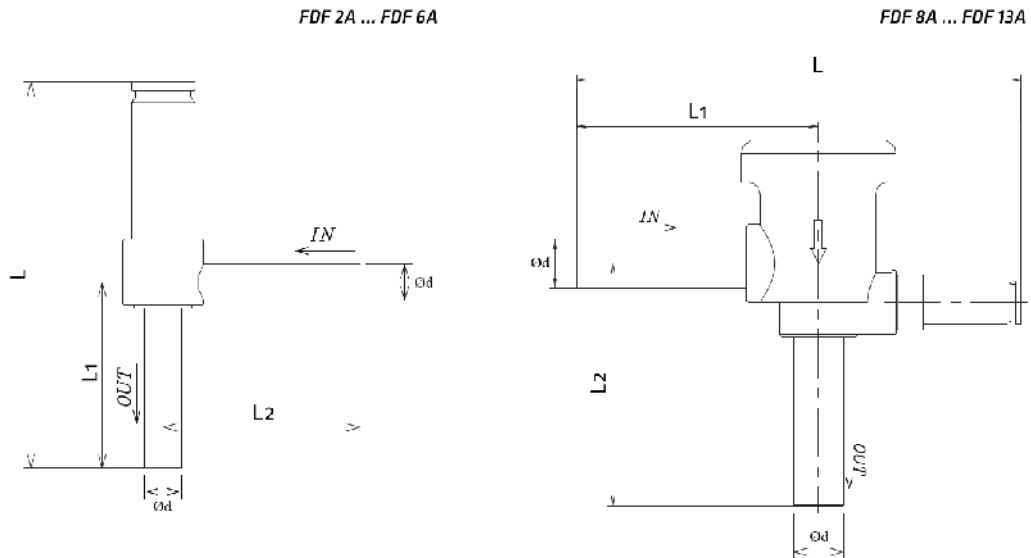

TECNHICAL PARAMETERS OF COIL

Model Coil	Part Number	Rated Voltage [V]	Supply	Power ¹⁾ [W]	Freq. [Hz]	Voltage Tolerance	Insulation Class	Wiring type
FQ-A05 024-000709	FQA-55001	24	AC	5 (50Hz) 4,5 (60Hz)	50/60	-15% +10%	B	flying leads
FQ-A05 120-001098	FQA-55002	110 to 120		5 (50Hz) 4,5 (60Hz)				
FQ-A05 22G-001044	FQA-55003	220 to 240		5 (50Hz) 4,5 (60Hz)				

Note:

1) Power consumption based on 220V

DIMENSIONS - COIL

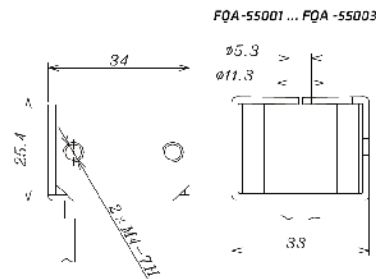

Solenoid Valve

FDF2AK series solenoid valves are direct operated, normally open solenoid valves, mainly used in refrigerant control of various devices such as refrigerating and freezing systems, air conditioners and heat pumps.

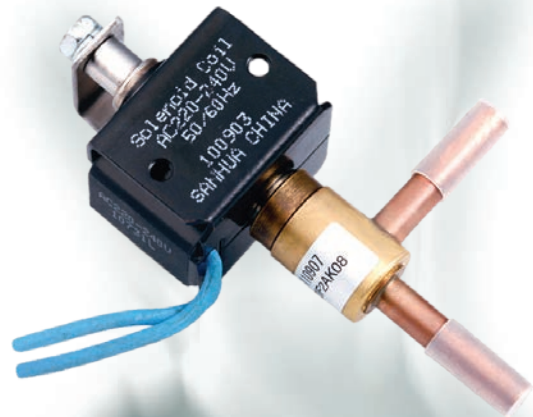

FEATURES

- COMPACT DESIGN
- LOW ENERGY CONSUMPTION
- EXCELLENT OPERATION PERFORMANCE

GENERAL SPECIFICATIONS

- Applicable for all common HCFC and HFC refrigerants such as: R22, R134a, R404A, R407C, R410A, R507A ...
- Medium temperature TS min./max.: -30°C / 120°C
- Ambient temperature: -30°C / +50°C
- Relative humidity: 0 to 95% RH
- Installation position:
 - Liquid, suction and discharge line
 - Coil upwards, coil axis $\pm 15^\circ$ tolerance versus vertical axis
 - Flow direction corresponds to the arrow
- Declaration according to LVD or PED

TECHNICAL PARAMETERS OF VALVE BODY

Valve Body Model	Part Number	Normal Position	Actuation	Ø Seat [mm]	Kv [m ³ /h]	MOP [MPa]	Max. OPD [MPa]	Min. OPD [MPa]	Connection OD Ød	
									[mm]	[inch]
FDF 2AK 01	FDF-06009	NO	Direct	1,8	0,05	4,5	1,5	0	6,35 ±0,1	1/4
FDF 2AK 08	FDF-06010			1,9	0,08					

FDF2AK (NO) SERIES Solenoid Valve



DIMENSIONS - VALVE BODY

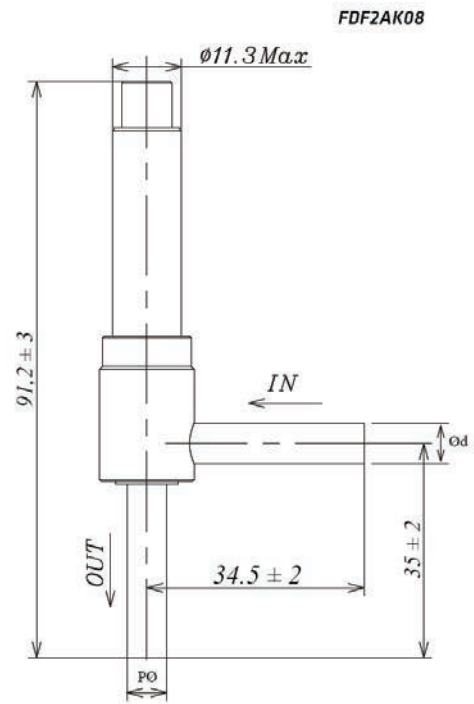
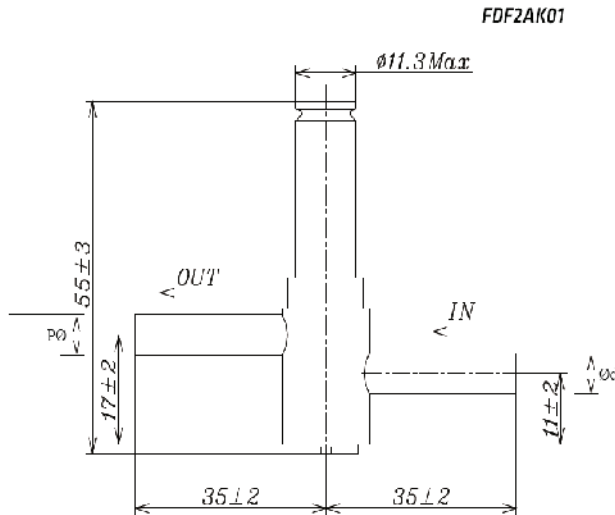

TECHNICAL PARAMETERS OF COIL

Coil Model	Part Number	Rated Voltage [V]	Supply	Power ³⁾ [W]	Used for	Freq. [Hz]	Voltage Tolerance	Insulation Class	Wiring type
FQ-A05024-000709	FQA-55001	24	AC	5 (50Hz) 4,5 (60Hz)	FDF 2AK 01 ¹⁾	50/60	-15% +10%	B	flying leads
FQ-A05120-001098	FQA-55002	110 to 120		5 (50Hz) 4,5 (60Hz)					
FQA-0522G-001044	FQA-55003	220 to 240		5 (50Hz) 4,5 (60Hz)					
FQA-0522G-001066	FQA-55007	220 to 240		6,5 (50Hz) 5 (60Hz)	FDF 2AK 08 ²⁾				

Note:

- 1) Dimensions: drawing 1
- 2) Dimensions: drawing 2
- 3) Power consumption based on 220V

FDF2AK (NO) SERIES
Solenoid Valve



DIMENSIONS - COIL

Drawing 1: FQA-55001, -55002, -55003

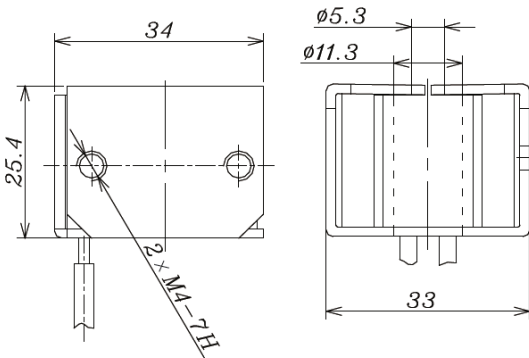

Drawing 2: FQA-55007

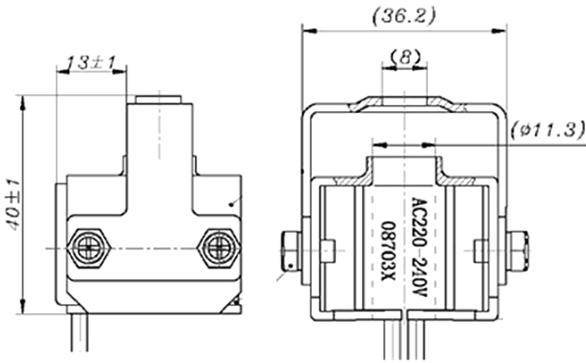



HI I'M SOLY, THE SANHUA SOLENOID VALVE, I CAN HELP YOU TO FIND SANHUA'S BEST SOLUTION FOR YOU



SANHUA



SELECTION TOOL



CROSS REFERENCE TOOL



SANHUA Selection Tool gives you the possibility to identify the best component suitable in our range which covers your system requirement.

DOWNLOAD it and make your system design easy using this intuitive Sanhua Tool.

314133026525 8070323848 2643383279
5232078164 0628620999 8620034825
3421170579 82148008651 3282306547
0938446095 5058223172 5329406128

SANHUA with the collaboration of his dealers and technical team makes you easy to identify our products compared to other components and brands in the market.

Don't forget to double check if our suggestion covers your entire requirements.



*Every 2nd home refrigerator
in Europe is equipped*

with a SANHUA
solenoid valve

**YEARLY SANHUA SUPPLIES OVER
20 MILLION SOLENOID VALVES TO
THE REFRIGERATION, HVAC AND
HOME APPLIANCES INDUSTRIES
WORLDWIDE**



**DISCOVER
WHY**

www.sanhuaeurope.com



 **SANHUA**

CHILLING IDEAS WORLDWIDE

SANHUA INTERNATIONAL EUROPE
info@sanhuaeurope.com

Thermostatic Expansion Valve

RFKA series thermostatic expansion valves are used to adjust mass flow of refrigerant into the evaporator while controlling the refrigerant's superheat at the outlet of the evaporator. They can be used for various refrigerants under all working conditions. Typical applications are refrigeration systems like freezers, ice makers, dehumidifiers as well as air conditioners and heat pumps at various evaporation temperature ranges.



FEATURES

- EXCHANGEABLE VALVE ORIFICE, EASY TO STOCK HOLDING, CONVENIENT FOR CAPACITY MATCH AND REPAIR
- THERMAL BULB UTILIZES CROSS CHARGE TECHNOLOGY, PROVIDING CONSISTENT SUPERHEAT DEGREE OVER THE WHOLE EVAPORATION TEMPERATURE RANGE
- VALVES WITH MOP FUNCTION CAN BE PROVIDED TO ASSURE RELIABLE COMPRESSOR OPERATION
- APPLICABLE IN A WIDE EVAPORATION TEMPERATURE RANGE
- RELIABLE AND CONSISTENT PERFORMANCE OF SUPERHEAT CONTROL

GENERAL SPECIFICATIONS

- Applicable for all common HCFC and HFC refrigerants such as: R22, R134a, R404A, R407C, R507A ...
- Medium temperature TS min./max.: -40°C/+70°C
- Max. operating pressure PS: 2,1 ... 3,5 MPa (21 ... 35 bar)
- Installation position:
 - Preferably valve head upwards
 - Flow direction from inlet A to outlet B
- Certifications: UL/CSA and PED declaration

TECHNICAL PARAMETERS

- RFKA series angle shape valve
- Inlet 3/8" flare connection
- Capillary tube length 1,5m
- Equalization port:
 - RFKA flare/flare type with 1/4" flare connection;
 - RFKA flare/solder type with 6mm solder connection

RFKA SERIES

Thermostatic Expansion Valve



MODEL DESIGNATION LEGEND

Position Number	Model Designation Legend	
1	Product Code	Product Series
	RFKA	Thermostatic expansion valve
2	Refrigerant	Description
	01	R22
	02	R407C
	03	R404A / R507A
3	04	R134a
	Pressure Equalization	Description
	E	External pressure equalization
4	(Omitted)	Internal pressure equalization
	Miscellaneous	Description
4	xxxx	Digits for additional information

MODEL DESIGNATION EXAMPLE

Position Number				According to Model Designation Legend
1	2	3	4	
RFKA	01	E	xxxx	Thermostatic expansion valve
RFKA	01	E	xxxx	Refrigerant R22
RFKA	01	E	xxxx	Connection for external pressure equalization
RFKA	01	E	xxxx	Digits for additional information

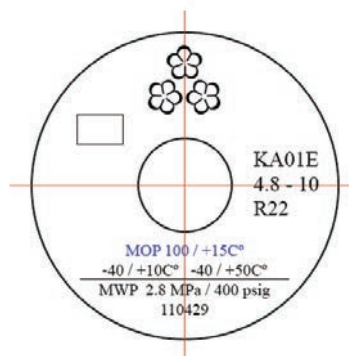

RFKA SERIES

Thermostatic Expansion Valve



TECHNICAL PARAMETERS

Ref. PS [MPa]	Model Valve Body	Part Number ¹⁾	Connection type	Temp. Range ²⁾	MOP ³⁾	Inlet ØA	Outlet ⁴⁾ ØB			Ext. ØC	
			In / Out / Ext. Pressure Equal.	[°C]	[°C]	flare	Flare	Solder		Flare	Solder
						[inch]	[inch]	[mm]	[inch]	[inch]	
R22 2,8	RFKA01-4.8-22	RFK-24001	flare / flare	+10 to -40	-	3/8	1/2	-	-	-	-
	RFKA01E-4.8-13	RFK-24002	flare / flare / flare				1/2	-	-	1/4	-
	RFKA01-4.8-26	RFK-24003	flare / solder				-	12	-	-	-
	RFKA01E-4.8-06	RFK-24004	flare / solder / solder				-	12	-	-	6
	RFKA01-4.8-07	RFK-24005	flare / solder				-	-	1/2	-	-
	RFKA01E-4.8-08	RFK-24006	flare / solder / solder				-	-	1/2	-	1/4
R407C 2,8	RFKA02-5.2-24	RFK-24007	flare / flare	+10 to -40	-	3/8	1/2	-	-	-	-
	RFKA02E-5.2-20	RFK-24008	flare / flare / flare				1/2	-	-	1/4	-
	RFKA02-5.2-27	RFK-24009	flare / solder				-	12	-	-	-
	RFKA02E-5.2-28	RFK-24010	flare / solder / solder				-	12	-	-	6
	RFKA02-5.2-32	RFK-24011	flare / solder				-	-	1/2	-	-
	RFKA02E-5.2-18	RFK-24012	flare / solder / solder				-	-	1/2	-	1/4
R404A / R507A 3,5	RFKA03-3.4-21	RFK-24013	flare / flare	+10 to -40	-	3/8	1/2	-	-	-	-
	RFKA03E-3.4-15	RFK-24014	flare / flare / flare				1/2	-	-	1/4	-
	RFKA03-3.4-03	RFK-24015	flare / solder				-	12	-	-	-
	RFKA03E-3.4-02	RFK-24016	flare / solder / solder				-	12	-	-	6
	RFKA03-3.4--09	RFK-24017	flare / solder				-	-	1/2	-	-
	RFKA03E-3.4-10	RFK-24018	flare / solder / solder				-	-	1/2	-	1/4
R134a 2,1	RFKA04-4.0-23	RFK-24019	flare / flare	+10 to -40	-	3/8	1/2	-	-	-	-
	RFKA04E-4.0-19	RFK-24020	flare / flare / flare				1/2	-	-	1/4	-
	RFKA04-4.0-29	RFK-24021	flare / solder				-	12	-	-	-
	RFKA04E-4.0-17	RFK-24022	flare / solder / solder				-	12	-	-	6
	RFKA04-4.0-30	RFK-24023	flare / solder				-	-	1/2	-	-
	RFKA04E-4.0-31	RFK-24024	flare / solder / solder				-	-	1/2	-	1/4

Note:

- 1) Extent of delivery: valve body and bulb strap
- 2) Different evaporation temperature range on request
- 3) MOP function on request

RFKA SERIES

Thermostatic Expansion Valve

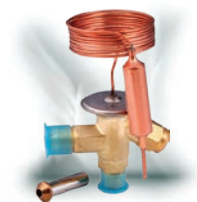

DIMENSIONS

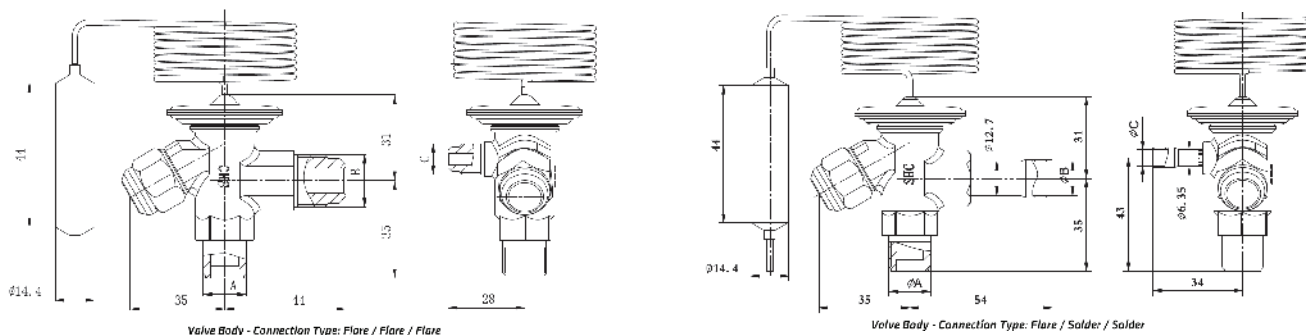

ACCESSORIES

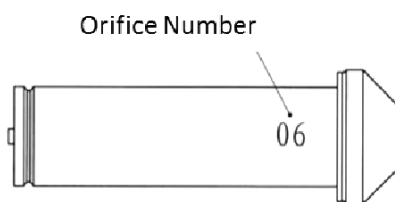

ORIFICE

Orifice Number	Nominal Capacity ¹⁾ [kW]				Valve Orifice Model	Valve Orifice Part Number
	R22	R407C ²⁾	R404A / R507A	R134a		
0X	0,5	0,5	0,35	0,33	RFKA-023-0X	RFK-24036
0	1,1	1,1	0,7	0,68	RFKA-023-00	RFK-24037
1	2,5	2,7	1,7	1,6	RFKA-023-01	RFK-24038
2	3,5	3,9	2,4	2,2	RFKA-023-02	RFK-24039
3	5,6	6,3	3,9	3,5	RFKA-023-03	RFK-24040
4	8,1	8,8	5,6	4,9	RFKA-023-04	RFK-24041
5	10,6	11,3	7,4	6,7	RFKA-023-05	RFK-24042
6	16,9	18,3	12	10,6	RFKA-023-06	RFK-24043

Note:

1) Nominal working conditions: Condensing temperature: 38°C; evaporating temperature 5°C; subcooling 4K; operational superheat 4K

2) R407C data based on dew point conditions

RFKA SERIES
Thermostatic Expansion Valve

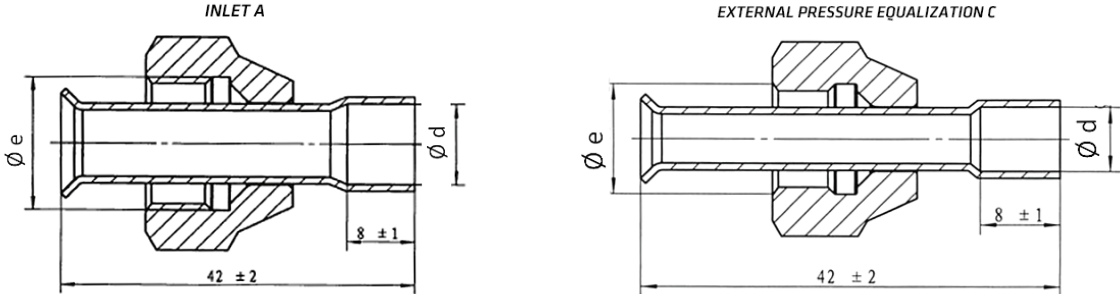

SOLDER ADAPTERS FOR RFKA INLET A

Model	Part Number	SAE Flare Ø e	Solder Connection Ø d
RFKA-038-01	RFK-24044	3/8"	3/8"
RFKA-038-02	RFK-24045		10mm
RFKA-038-05	RFK-24048		1/4"
RFKA-038-06	RFK-24049		6mm

SOLDER ADAPTERS FOR RFKA EXTERNAL PRESSURE EQUALIZATION C

Model	Part Number	SAE Flare Ø e	Solder Connection Ø d
RFKA-038-03	RFK-24046	1/4"	6mm
RFKA-038-04	RFK-24047		1/4"

FLARE NUTS FOR RFKA

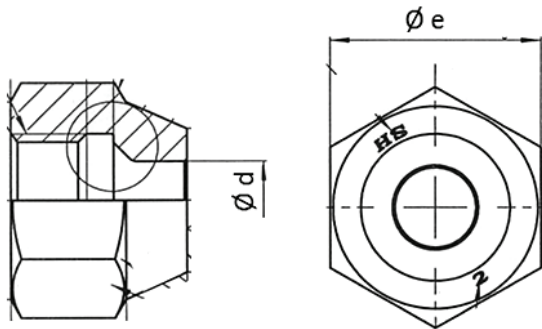

Model	Part Number	SAE Flare	Pipe Diameter Ø d		Wrench Size Ø e
		[inch]	[mm]	[inch]	[mm]
ZZ4-0107721	RFK-24050	1/4	6	1/4	17
ZZ4-0107723	RFK-24051	3/8	-	3/8	22
ZZ4-0107724	RFK-24052	1/2	12	1/2	24

Ball Valve

The ball valve of series SBV is applicable for commercial air conditioner, freezing or deep-freezing equipment or other refrigeration circuits in order to open and to shut off inner flow path by operating the valve stem. It can also be used as service valve for vacuum pumping and refrigerant injection etc.

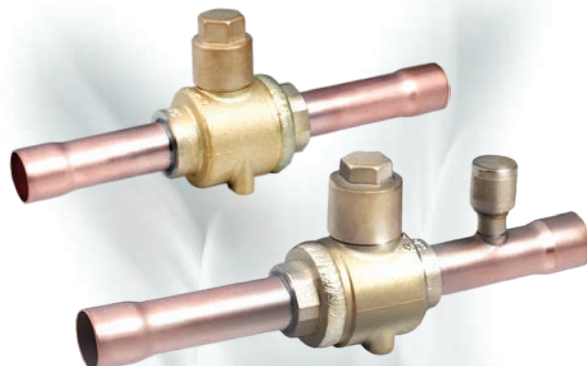

FEATURES

- STRAIGHTWAY TYPE, FULL PORT, LOW PRESSURE DROP , COST-EFFECTIVE
- OPTIONAL WITH REINFORCED SPRING
- VALVE BODY AND VALVE SEAT WITH WELDED STRUCTURE, WITH HIGH PRODUCT RELIABILITY
- ROTATE 1/4 CIRCLES FROM FULL-OPEN TO FULL-CLOSE, EASY TO OPERATE
- BIDIRECTIONAL FLOW
- ROTATION STOP ON REQUEST FOR FULL-OPEN AND FULL-CLOSE OF THE VALVE
- SPECIAL SEALING MATERIALS TO PREVENT INTERNAL LEAKAGE

GENERAL SPECIFICATIONS

- Applicable for all common HCFC and HFC refrigerants such as: R22, R134a, R404A, R407C, R410A, R507A ...
- Medium temperature TS min./max.: -40°C / +120°C
- Max. operating pressure PS: 4,5 MPa (45 bar)
- Installation position: liquid, suction and discharge line in all directions
- Certifications: UL/CSA and PED declaration

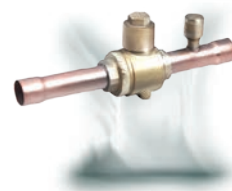

GENERAL CHARACTERISTICS

Without Access Fitting		Connections Ø d ODF		Kv	Wrench Size Cap	PED category	With Access Fitting	
Model	Product Number	[inch]	[mm]	[m ³ /h]	[mm]		Model	Product Number
SBV(M)-A2YHSY-2-S	SBV-13001	-	6	1,9	14	3.3	SBV(M)-JA2YHSY-2-S	SBV-13019
SBV(M)-A2YHSY-1-S	SBV-13002	1/4	-	1,9	14	3.3	SBV(M)-JA2YHSY-1-S	SBV-13020
SBV(M)-A3YHSY-2-S	SBV-13037	3/8	-	5,5	14	3.3	SBV(M)-JA3YHSY-2-S	SBV-13039
SBV(M)-A3YHSY-1-S	SBV-13003	-	10	5,5	14	3.3	SBV(M)-JA3YHSY-1-S	SBV-13021
SBV(M)-A4YHSY-2-S	SBV-13004	-	12	10,2	14	3.3	SBV(M)-JA4YHSY-2-S	SBV-13022
SBV(M)-A4YHSY-1-S	SBV-13005	1/2	-	10,2	14	3.3	SBV(M)-JA4YHSY-1-S	SBV-13023
SBV(M)-A5YHSY-2-S	SBV-13006	-	15	13,2	14	3.3	SBV(M)-JA5YHSY-2-S	SBV-13024
SBV(M)-A5YHSY-1-S	SBV-13007	5/8	16	13,8	14	3.3	SBV(M)-JA5YHSY-1-S	SBV-13025
SBV(M)-A6YHSY-2-S	SBV-13008	-	18	19,5	17	3.3	SBV(M)-JA6YHSY-2-S	SBV-13026
SBV(M)-A6YHSY-1-S	SBV-13009	3/4	-	19,5	17	3.3	SBV(M)-JA6YHSY-1-S	SBV-13027
SBV(M)-A7YHSY-1-S	SBV-13010	7/8	22	28,0	17	3.3	SBV(M)-JA7YHSY-1-S	SBV-13028
SBV(M)-A9YHSY-2-S	SBV-13011	-	28	51,5	17	3.3	SBV(M)-JA9YHSY-2-S	SBV-13029
SBV(M)-A9YHSY-1-S	SBV-13012	1 1/8	-	51,5	17	3.3	SBV(M)-JA9YHSY-1-S	SBV-13030
SBV(M)-A11YHSY-1-S	SBV-13013	1 3/8	35	80,0	17	I	SBV(M)-JA11YHSY-1-S	SBV-13031
SBV(M)-A13YHSY-2-S	SBV-13038	1 5/8	-	119,8	17	I	SBV(M)-JA13YHSY-2-S	SBV-13040
SBV(M)-A13YHSY-1-S	SBV-13014	-	42	119,8	17	I	SBV(M)-JA13YHSY-1-S	SBV-13032
SBV(M)-A17YHSY-1-S	SBV-13015	2 1/8	54	225	19	I	SBV(M)-JA17YHSY-1-S	SBV-13033
SBV(M)-A19YHSY-1-S	SBV-13016	-	64	225	19	I	SBV(M)-JA19YHSY-1-S	SBV-13034
SBV(M)-A21YHSY-2-S	SBV-13017	2 5/8	-	305	19	I	SBV(M)-JA21YHSY-2-S	SBV-13035
SBV(M)-A25YHSY-2-S	SBV-13018	3 1/8	80	635	24	I	SBV(M)-JA25YHSY-2-S	SBV-13036
SBV(M)-A29YHSY-1-S	SBV-13041	3 5/8	92	805	26	I	SBV(M)-JA29YHSY-1-S	SBV-13043
SBV(M)-A33YHSY-2-S	SBV-13046	4 1/8	105	950	32	I	SBV(M)-JA33YHSY-2-S	SBV-13045
SBV(M)-A34YHSY-1-S	SBV-13042	4 1/4	108	950	32	I	SBV(M)-JA34YHSY-1-S	SBV-13044

Note: SBV model with connection size 3-1/2" (89mm) available on request

SBV SERIES Ball Valve

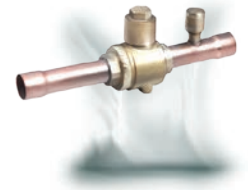
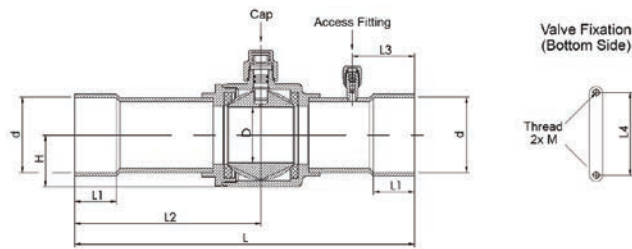

DIMENSIONS & WEIGHT

Product Number		L	L1	L2	L3 ¹⁾	L4	D	H	M	Weight
Without access fitting	With Access Fitting	[mm]	[mm]	[mm]	[mm]	[mm]	[mm]	[mm]	[mm]	[kg]
SBV-13001	SBV-13019	132	8	68	31	22	14	16	M4 x 0,7	0,28
SBV-13002	SBV-13020	132	8	68	31	22	14	16	M4 x 0,7	0,28
SBV-13037	SBV-13039	132	8	68	31	22	14	16	M4 x 0,7	0,29
SBV-13003	SBV-13021	132	8	68	31	22	14	16	M4 x 0,7	0,29
SBV-13004	SBV-13022	160	10	85	31	22	14	16	M4 x 0,7	0,30
SBV-13005	SBV-13023	160	10	85	31	22	14	16	M4 x 0,7	0,30
SBV-13006	SBV-13024	160	12	85	31	22	14	16	M4 x 0,7	0,30
SBV-13007	SBV-13025	160	12	85	31	22	14	16	M4 x 0,7	0,30
SBV-13008	SBV-13026	185	14	99	37	30	19	20	M4 x 0,7	0,51
SBV-13009	SBV-13027	185	14	99	37	30	19	20	M4 x 0,7	0,51
SBV-13010	SBV-13028	185	17	99	37	30	19	20	M4 x 0,7	0,52
SBV-13011	SBV-13029	208	20	112	44	38	25	25	M4 x 0,7	0,73
SBV-13012	SBV-13030	208	20	112	44	38	25	25	M4 x 0,7	0,73
SBV-13013	SBV-13031	251	25	136	44	48	32	31	M6 x 1,0	1,42
SBV-13038	SBV-13040	281	29	151	56	55	38	35	M6 x 1,0	1,90
SBV-13014	SBV-13032	281	29	151	56	55	38	35	M6 x 1,0	1,90
SBV-13015	SBV-13033	305	34	167	56	74	50	46	M6 x 1,0	3,74
SBV-13016	SBV-13034	305	34	167	70	74	50	46	M6 x 1,0	3,79
SBV-13017	SBV-13035	305	37	167	56	74	60	56	M6 x 1,0	6,08
SBV-13018	SBV-13036	378	42	186,2	80	90	70	63	M6 x 1,0	8,81
SBV-13041	SBV-13043	422,7	42	207,5	75	108	80	75	M6 x 1,0	11,32
SBV-13046	SBV-13045	423	42	210,0	75	148	95	91	M6 x 1,0	19,94
SBV-13042	SBV-13044	423	42	210,0	75	148	95	91	M6 x 1,0	19,94

Note: 1) Applicable to versions with access fitting - SBV(M)-JA series

ACCESSORIES

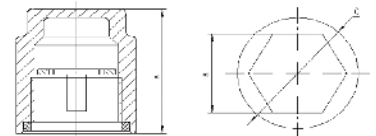

Anti-Rotation Device

Model	Product Number	Applicable for SBV models with:		Cap Nut	Dimensions mm		
		Inch connections:	Metric connections:		A	B	C
SK01	SBV-13101	1" 1/8 - 1" 3/8	28mm - 35mm	M18X1-6H	27,0	H17	Ø 24
SK02	SBV-13102	1" 5/8	42mm	M22X1-6H	27,5	H17	Ø 26
SK03	SBV-13103	2" 1/8 - 2" 5/8	54mm - 64mm	M22X1-6H	27,5	H19	Ø 28
SK04	SBV-13104	3" 1/8 - 3" 5/8	80mm - 92mm	M26X1-6H	29,5	H24	Ø 32
SK05	SBV-13105	4" 1/8 - 4" 1/4	105mm - 108mm	M32X1-6H	32,0	H29	Ø 38

Check Valve Piston Type

Piston type check valves are designed for installation in commercial refrigerating systems and in residential or industrial air conditioning plants. They are used to control the unidirectional flow of refrigerant so as to prevent backflow.

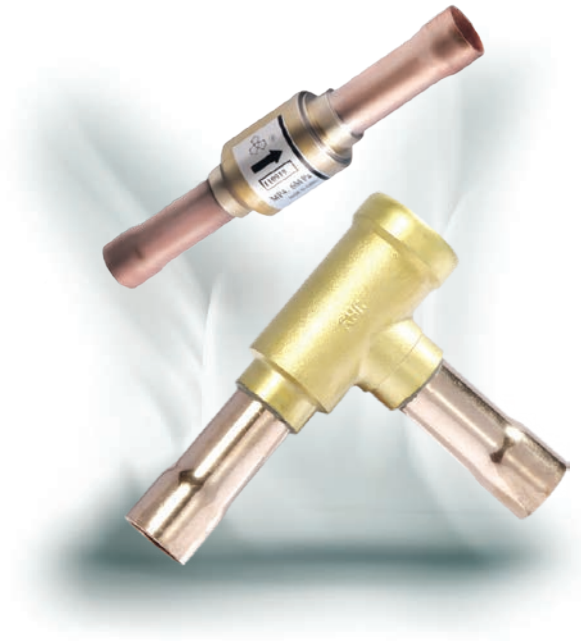

FEATURES

- THIS VALVE CAN ENSURE THE ONLY CORRECT FLOW DIRECTION
- EQUIPPED WITH DAMPING SPRING TO FREELY INSTALL THE VALVE AT POSITIONS WITH PRESSURE PULSE
- AVAILABLE IN TWO TYPES OF MODEL: STRAIGHTWAY VALVE AND L-SHAPE VALVE, EASY TO CONNECT
- SPECIAL VERSION OF CHECK VALVE EQUIPPED WITH REINFORCED SPRING AVAILABLE, APPLICABLE TO COMPRESSOR DISCHARGE PIPES IN SINGLE OR MULTI COMPRESSOR SYSTEMS (YCVSH SERIES)
- LOW PRESSURE DROP DURING OPERATION

GENERAL SPECIFICATIONS

- Applicable for all common HCFC and HFC refrigerants such as: R22, R134a, R404A, R407C, R410A, R507A ...
- Medium temperature TS min./max.: -50°C / +140°C
- Max. operating pressure PS: 4,6 MPa (46 bar)
- Installation position:
 - Flow direction corresponds to the arrow
 - Straight-way type: preferably installed with vertical axis and flow upwards, sloping axis up to horizontal is tolerable
 - L-shape type: flow direction from bottom to top
- Declaration according to PED

YCV SERIES

Check Valve Piston Type



GENERAL CHARACTERISTICS

Model	Part Number	Type	Connections ODF		Kv	Min. OPD	Dimensions			PED category
			Ø d				ØD	C	E	
			[inch]	[mm]	[m³/h]	[kPa]				
YCVS 5-11GSHC-1	YCV-15001	straight-way	-	6	0,56	5	5	90	18	3,3
YCVS 5-22GSHC-1	YCV-15002	straight-way	1/4	-	0,56	5	5	90	18	3,3
YCVS 8-33GSHC-1	YCV-15007	straight-way	3/8	-	1,43	5	8	110	18	3,3
YCVSH 8-33GSHC-1	YCV-15008	straight-way	3/8	-	1,43	15	8	110	18	3,3
YCVS 8-33GSHC-2	YCV-15009	straight-way	-	10	1,43	5	8	110	18	3,3
YCVSH 8-33GSHC-2	YCV-15010	straight-way	-	10	1,43	15	8	110	18	3,3
YCVS 10-33GSHC-1	YCV-15015	straight-way	-	12	2,1	5	10	130	22	3,3
YCVSH 10-33GSHC-1	YCV-15016	straight-way	-	12	2,1	15	10	130	22	3,3
YCVS 10-44GSHC-1	YCV-15017	straight-way	1/2	-	2,1	5	10	130	22	3,3
YCVSH10-44GSHC-1	YCV-15018	straight-way	1/2	-	2,1	15	10	130	22	3,3
YCVS 13-55GSHC-1	YCV-15021	straight-way	5/8	16	3,9	5	13	140	28	3,3
YCVSH 13-55GSHC-1	YCV-15022	straight-way	5/8	16	3,9	15	13	140	28	3,3
YCVS 17-55GSHC-1	YCV-15027	straight-way	-	18	5,52	5	17	165	34	3,3
YCVSH 17-55GSHC-1	YCV-15028	straight-way	-	18	5,52	15	17	165	34	3,3
YCVS 17-66GSHC-1	YCV-15029	straight-way	3/4	-	5,52	5	17	165	34	3,3
YCVSH 17-66GSHC-1	YCV-15030	straight-way	3/4	-	5,52	15	17	165	34	3,3
YCVS 17-77GSHC-1	YCV-15051	straight-way	7/8	22	5,52	5	17	165	34	3,3
YCVSH 17-77GSHC-1	YCV-15052	straight-way	7/8	22	5,52	15	17	165	34	3,3
YCVS 20-77GSHC-1	YCV-15033	L-shape	7/8	22	13,2	10	20	132	87	3,3
YCVSH 20-77GSHC-1	YCV-15034	L-shape	7/8	22	13,2	30	20	132	87	3,3
YCVS 26-88GSHC-1	YCV-15039	L-shape	-	28	19,02	10	26	196	123	3,3
YCVSH 26-88GSHC-1	YCV-15040	L-shape	-	28	19,02	30	26	196	123	3,3
YCVS 26-99GSHC-1	YCV-15041	L-shape	1 1/8	-	19,02	10	26	196	123	3,3
YCVSH 26-99GSHC-1	YCV-15042	L-shape	1 1/8	-	19,02	30	26	196	123	3,3
YCVS 31-BBGSHC-1	YCV-15045	L-shape	1 3/8	35	29,1	10	31	196	123	I
YCVSH 31-BBGSHC-1	YCV-15046	L-shape	1 3/8	35	29,1	30	31	196	123	I
YCVS 31-DDGSHC-1	YCV-15047	L-shape	1 5/8	-	29,1	10	31	196	123	I
YCVSH 31-DDGSHC-1	YCV-15048	L-shape	1 5/8	-	29,1	30	31	196	123	I
YCVS 31-DDGSHC-2	YCV-15049	L-shape	-	42	29,1	10	31	196	123	I
YCVSH 31-DDGSHC-2	YCV-15050	L-shape	-	42	29,1	30	31	196	123	I

YCV SERIES

Check Valve Piston Type



GENERAL CHARACTERISTICS

Straight-way

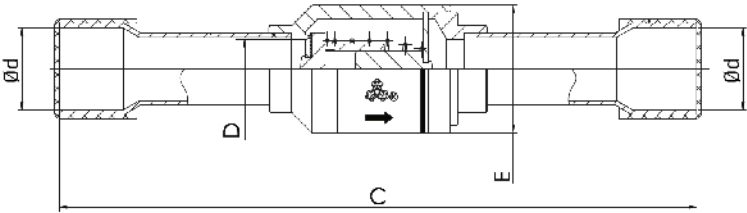

L-shape

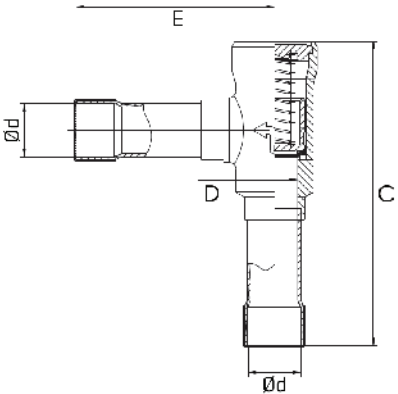

Every 2nd home refrigerator
in Europe is equipped
with a **SANHUA**
solenoid valve



DISCOVER
WHY

www.sanhuaeurope.com

YEARLY SANHUA SUPPLIES OVER 20 MILLION SOLENOID
VALVES TO THE REFRIGERATION, HVAC AND HOME
APPLIANCES INDUSTRIES WORLDWIDE

*Every second A/C system
in the world is equipped with*
Inverter Technology

**SANHUA IS PROVIDING INVERTER
CONTROLLER SOLUTIONS TO
ITS CUSTOMERS HELPING THEM TO
IMPROVE SYSTEM EFFICIENCY
BY UP TO 30%**



DISCOVER
WHY

www.sanhuaeurope.com

 **SANHUA**

CHILLING *IDEAS* WORLDWIDE

SANHUA INTERNATIONAL EUROPE
info@sanhuaeurope.com

Sight Glass

Sight glasses are installed after the filter drier in liquid line of refrigerating systems, in order to observe property changes of the refrigerant (liquid/vapor) and to indicate the moisture level by colors.



FEATURES

- HIGH PRECISION COLOR INDICATOR
- INDICATOR PASTED CLOSELY TO THE GLASS TO PREVENT SURFACE CONTAMINATION
- SOLID AND CORROSION RESISTANT BRASS MATERIAL
- GOOD READABILITY DUE TO HIGH CLEAR SIGHT GLASS OF WIDE ANGLE
- SEALING OF LOW CREEP PTFE TO ENSURE LEAKAGE FREE PERFORMANCE

GENERAL SPECIFICATION

- Applicable for all common HCFC and HFC refrigerants such as: R22, R134a, R404A, R407C, R410A, R507A ...
- Ambient temperature min./max.: -50°C / +80°C
- Medium temperature TS min./max.: -50°C / +80°C
- Max. operating pressure PS: 4,6 MPa (46 bar)

- Installation position:
 - Liquid and suction line
 - Preferably in vertical lines, recommended position for horizontal lines is upwards without inclination in any direction
- Declaration according to PED

GENERAL CHARACTERISTICS

Version with female/female Solder Connections

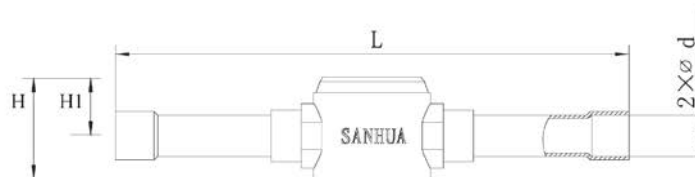



Version with female/female Solder Connections

Model ODF Solder	Connection Type	Connections ODF		Dimensions & Weight				PED Category	Product Number
		Ød		L	H	H1	Weight		
		[inch]	[mm]	[mm]	[mm]	[mm]	[g]		
SYJ-A00061-000	solder	-	6	101	24	14	100	3.3	SYJ-42001
SYJ-A00040-000	solder	1/4	-	101	24	14	100	3.3	SYJ-42002
SYJ-A00060-000	solder	3/8	-	119	24	14	100	3.3	SYJ-42003
SYJ-A00101-000	solder	-	10	119	24	14	100	3.3	SYJ-42004
SYJ-A00080-000	solder	1/2	-	146	30	17	200	3.3	SYJ-42005
SYJ-A00121-000	solder	-	12	146	30	17	200	3.3	SYJ-42006
SYJ-A00100-000	solder	5/8	16	146	30	17	200	3.3	SYJ-42007
SYJ-A00120-000	solder	3/4	-	173	37	21	300	3.3	SYJ-42008
SYJ-A00140-000	solder	7/8	22	173	37	21	300	3.3	SYJ-42009

Version with male/male Flare Connections

Model Flare	Connection Type	SAE Flare	Dimensions & Weight				PED Category	Drawing	Product Number
		Ød	L	H	ØD	Weight			
		[inch]	[mm]	[mm]	[mm]	[g]			
SYJ-A02040-000	flare	1/4	67	24	14	110	3.3	A	SYJ-42010
SYJ-A02060-000	flare	3/8	82	24	14	240	3.3	A	SYJ-42011
SYJ-A02080-000	flare	1/2	88	30	17	240	3.3	A	SYJ-42012
SYJ-A02100-000	flare	5/8	104	30	17	320	3.3	A	SYJ-42013
SYJ-A02120-000	flare	3/4	110	32	15	340	3.3	B	SYJ-42014

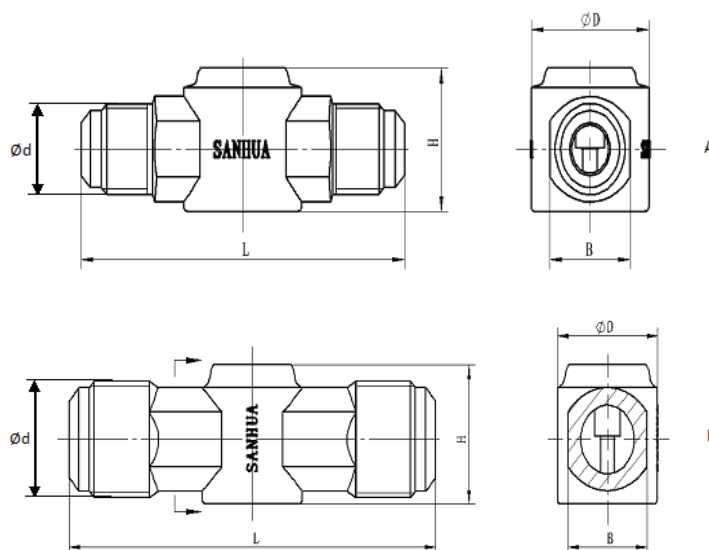



Version with male/female Flare connections

Model male/female flare	Connection Type	SAE Flare	Dimensions & Weight					PED Category	Drawing	Product Number
		Ød	L	H	ØD	B	Weight			
		[inch]	[mm]	[mm]	[mm]	[mm]	[g]			
SYJ-A02040-100	flare	1/4	46	30	32	22	200	3,3	C	SYJ-42015
SYJ-A02060-100	flare	3/8	57	30	32	22	240	3,3	C	SYJ-42016
SYJ-A02080-100	flare	1/2	59	32	30	24	250	3,3	C	SYJ-42017
SYJ-A02100-100	flare	5/8	71	37	30	24	320	3,3	D	SYJ-42018
SYJ-A02120-100	flare	3/4	75	37	30	24	330	3,3	D	SYJ-42019

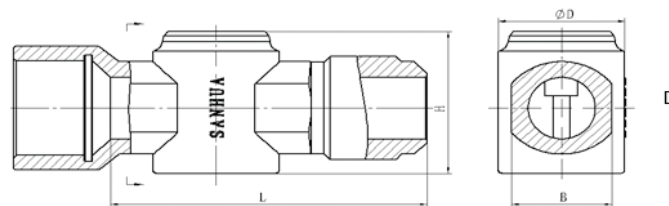
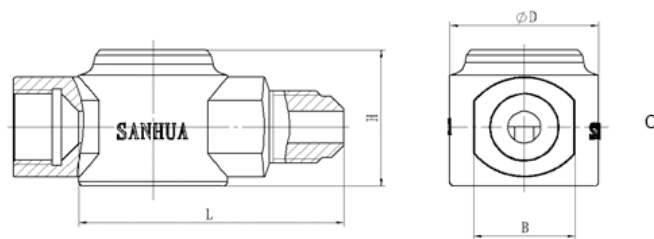

Every second A/C system
in the world is equipped with
Inverter Technology

DISCOVER
WHY

www.sanhuaeurope.com



**SANHUA IS PROVIDING INVERTER CONTROLLER SOLUTIONS TO
ITS COSTUMERS HELPING THEM TO IMPROVE SYSTEM
EFFICIENCY BY 30%**



Moisture Indication Limits

Refrigerant	Moisture Content 25°C: PMM		
	Green/Dry	Middle Color	Yellow/Wet
R22	<30	30~90	>90
R134a	<50	50~200	>200
R404A	<15	15~90	>90
R507	<15	15~90	>90
R407C	<120	120~280	>280
R410A	<75	75~150	>150

Refrigerant	Moisture Content 40°C: PMM		
	Green/Dry	Middle Color	Yellow/Wet
R22	<45	45~130	>130
R134a	<80	80~225	>225
R404A	<30	30~140	>140
R507	<30	30~140	>140

2 out of 3 AC units are equipped
with a SANHUA
reversing valve

DISCOVER
WHY

www.sanhuaeurope.com



YEARLY SANHUA SUPPLIES OVER 50 MILLION FOUR
WAY REVERSING VALVES TO THE COMMERCIAL AND
RESIDENTIAL HVAC INDUSTRY WORLDWIDE

Brass Service Valve

Brass service valves of series SSV are applicable for split air conditioners to connect indoor unit and outdoor unit. It can also be used in other cooling or refrigeration systems. The inner path of the valve can be closed by operating the valve stem. The 3way version (with charge port) can be used as service valve for vacuum pumping and refrigerant injection.



FEATURES

- AVAILABLE WITHOUT AND WITH CHARGE PORT
- COST EFFICIENT SOLUTION
- RELIABLE AND ROBUST DESIGN

GENERAL SPECIFICATIONS

- Applicable for all common HCFC and HFC refrigerants such as: R134a, R404A, R407C, R410A, R507A...
- Ambient temperature min./max.: -30°C / +55°C
- Medium temperature TS min./max.: -30 °C / +120°C
- Max. operating pressure PS: 4,5 MPa (45 bar)
- Installation position: Preferably liquid and suction line
- Certifications: UL/CSA and PED declaration

GENERAL CHARACTERISTICS

Model	Part Number ¹⁾	Connections					Cooling capacity [kW]	PED Category
		ØA Flare	Ød ODF		ØI Pipe	Charge Port Flare		
		[inch]	[inch]	[mm]	[mm]	[inch]		
SSV-A2GSHC-23	SSV-14001	7/16-20UNF	1/4	6,35	4,8	-	0,7 - 1,5	3,3
SSV-JA3GSHC-20	SSV-14002	5/8-18UNF	3/8	9,52	7,0	1/4	0,7 - 3,7	3,3
SSV-JA4GSHC-19	SSV-14003	3/4-16UNF	1/2	12,7	10	1/4	1,1 - 7,5	3,3
SSV-JA5GSHC-15	SSV-14004	7/8-14UNF	5/8	15,9	12,5	1/4	1,5 - 8,8	3,3
SSV-JA6GSHC-13	SSV-14005	1 1/16-14UNS	3/4	19,1	16	1/4	3,7 - 5,9	3,3

Note: 1) Extent of delivery:

- SSV-JA valve body with schrader valve, cap charge port, cap shut-off valve, nut pipe connection
- SSV-A valve body, cap shut-off valve, nut pipe connection, without charge port

SSV SERIES
Brass Service Valve



DIMENSIONS

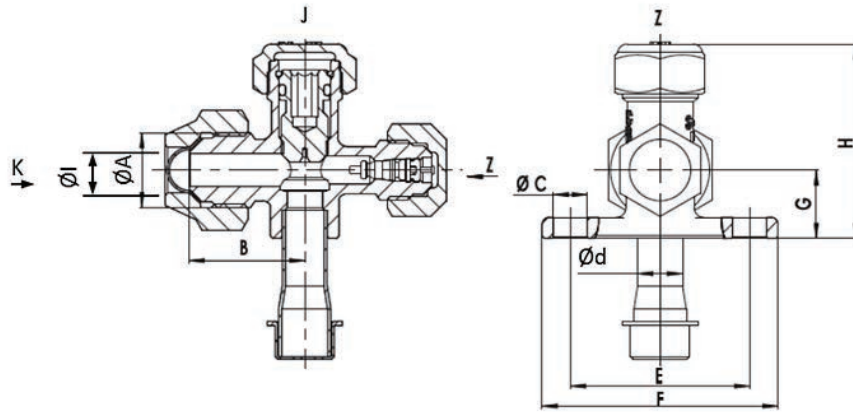

Model	Part Number	Dimensions [mm]						Wrench Size [mm]			
		B	ØC	E	F	G	H	Nut Pipe Connection K	Cap Shut-off Valve J	Valve ¹⁾ Steam J	Cap Charge Port Z
SSV-A2GSHC-23	SSV14001	23	7,2	38	50	14	36	19	17	5	-
SSV-JA3GSHC-20	SSV14002	24,5	7,2	38	50	14,5	41	22	19	5	17
SSV-JA4GSHC-19	SSV14003	28	7,2	38	50	16	44	24	22	5	17
SSV-JA5GSHC-15	SSV14004	34	7,2	38	50	17	47	27	26	5	17
SSV-JA6-GSHC-13	SSV14005	40	7,2	44	56	23	61	32	30	5	17

Note: 1) Allen screw

Every 4th car is equipped
with a SANHUA
expansion valve

DISCOVER
WHY

www.sanhuaeurope.com



YEARLY SANHUA SUPPLIES OVER 40 MILLION
THERMOSTATIC AND ELECTRONIC EXPANSION
VALVES TO THE HVAC & AUTOMOTIVE INDUSTRIES
WORLDWIDE

Charge Valve

Charge valves are mainly installed in air conditioning and refrigeration systems. They are used as service valve for circuit evacuation to vacuum and for refrigerant injection.

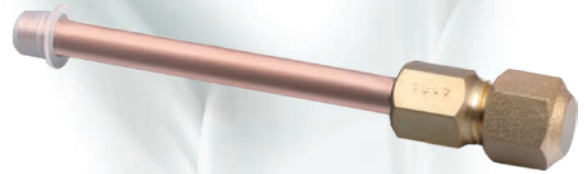

FEATURES

- SIMPLE STRUCTURE, CONVENIENT TO USE
- PREVENT REFRIGERANT LOSS THROUGH INTEGRATED SHRADER VALVE

GENERAL SPECIFICATION

- Applicable for all common HCFC and HFC refrigerants such as: R22, R134a, R404A, R407C, R410A, R507A ...
- Ambient temperature min./max.: -30/+55°C
- Medium temperature TS min./max.: -30°C / +80°C
- Max. operating pressure PS: 4,5 MPa (45 bar)
- Installation position: liquid or suction line
- Declaration according to PED

DIMENSIONS

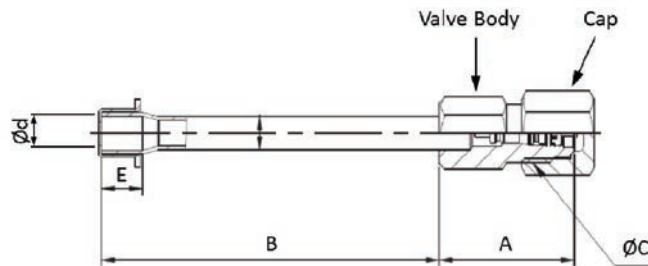

Model	Part Number ¹⁾	Connections			Dimensions			Wrench Size		Refrigerant
		Solder ODF Ød		Flare UNF ØC	A	B	E	Valve Body	Cap	
		[mm]	[inch]	[inch]	[mm]			[mm]		
TCJ-2HMSZ-1	TCJ-14001	6,35	1/4	7/16-20	26	65	8	12	14	R22
TCJ-2GMS-1	TCJ-14002	6,35	1/4	1/2-20	26	65	8	14	17	R134a/R404A/R407C R410A/R507

Note: 1) Extent of delivery: valve body, schrader valve and cap

TCJ SERIES Charge Valve

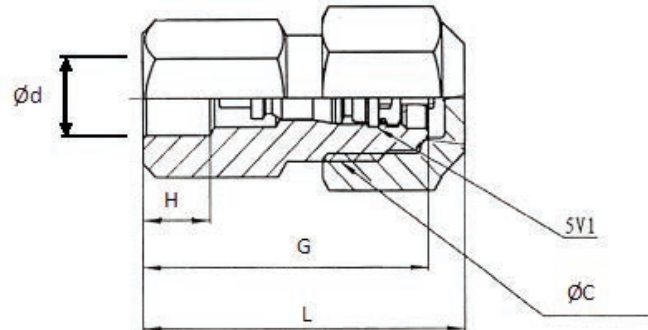
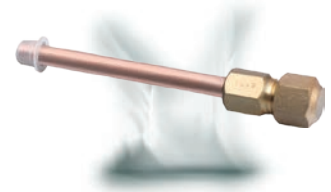

Model	Part Number ¹⁾	Connections			Dimensions			Wrench Size		Refrigerant
		Solder ODF Ød		Flare UNF ØC	L	G	H	Valve Body	Cap	
		[mm]	[inch]	[inch]	[mm]			[mm]		
TCJ-2HLEN-1	TCJ-14003	6,35	1/4	7/16-20	29	26	6	12	14	R22
TCJ-2GLEN-2	TCJ-14004	6,35	1/4	1/2-20	29	26	6	14	17	R134a/R404A/R407C R410A/R507

Note: 1) Extent of delivery: valve body and cap

**SANHUA is the world's largest
producer of
Micro-Channel Heat Exchangers**
for Stationary HVACe-R application

DISCOVER
WHY

www.sanhuaeurope.com



**SANHUA DELIVERS OVER 1,300,000 MCH
CONDENSERS (CO & HP) AND EVAPORATORS HELPING
TO IMPROVE SYSTEM EFFICIENCY BY UP TO 30%**

Uni-Flow Filter Driers

The filter driers of series DTG are used in refrigeration system with unidirectional flow to absorb moisture and acid in the system and to filter out the impurities.



FEATURES

- HIGH EFFICIENT IN MOISTURE ABSORPTION, FILTERING IMPURITY, ACID, PAINT REMAINS AND MUD REMOVAL
- HYBRID DESICCANT
- DURABLE AND SOLID FILTER CORES
- FILTERING FINENESS: 20µm
- CORROSION RESISTANT PAINTING SURVIVES SALT SPRAY TEST OF 500 HOURS
- CONNECTION TYPE: FLARE OR SOLDER

GENERAL SPECIFICATIONS

- Applicable for all common HCFC and HFC refrigerants such as: R22, R134a, R404A, R407C, R410A, R507A ...
- Ambient temperature min./max.: -30°C / +55°C
- Medium temperature TS min./max.: -30°C / +120°C
- Max. operating pressure PS max.: 4,83 MPa (48,3 bar) - 700 PSI
- Installation position:
 - Flow direction corresponds to the arrow
 - Preferably installed in liquid line
- Certifications: UL/CSA and PED declaration

TECHNICAL PARAMETERS *Desiccant Selection Table*

	Medium Type	80% 3Å desiccant and 20% active alumina	100% 3Å desiccant
Refrigerant ¹	HFC	Applicable	Applicable
	HCFC	Applicable	Applicable
	CFC	Applicable	Not Applicable
Oil ²	Mineral oil or AB	Applicable	Applicable
	Pure POE or PAG	Applicable	Applicable
	POE or PAG with additive	Not Applicable	Applicable

Note: 1) For CFC system, usage of core with alumina is recommended as a strong capability to absorb acid may be needed
 2) When the systems use oil with additive, it is not recommended to use a core with alumina.

DTG/L SERIES

Uni-Flow Filter Driers



Model Designation Legend

1	Product Code	Filter Drier Series	
	DTG	Indicates unidirectional filter drier	
2	Filter Core	Structure and Material	
	A	Loos core, 100%3Å desiccant	
	B	Solid core, 100%3Å desiccant	
	E	Loos core, 80% 3Å desiccant and 20% active alumina	
	F	Solid core, 80% 3Å desiccant and 20% active alumina	
3	Internal Volume	Expressed in [inch³]	Expressed in [cm³]
	03	3	49
	05	5	82
	08	8	131
	16	16	262
	30	30	492
	41	41	672
	75	75	1229
4	Connection Size	Pos. 5 shows "0": Solder [inch]	Pos. 5 shows "4": SAE Flare [inch]
	02	1/4	1/4
	25	5/16	-
	03	3/8	3/8
	04	1/2	1/2
	05	5/8	5/8
	06	3/4	3/4
	07	7/8	7/8
	09	1 1/8	-
	Connection Size	Pos. 5 shows "1": Solder [mm]	
	06	6	
	(08) *	(5/16" version can be used e.g. DTG-B03 250)	
	10	10	
	12	12	
	16	16	
	(22) *	(7/8" version can be used e.g. DTG-B16 070)	
	28	28	
5	Pipe Connection	Type	
	0	Solder with inch connections	
	1 *	Solder with metric connections	
	4	SAE flare connections	
6	Version Number	Description	
	901	Standard product	

Note: * Solder connections which fit to metric and inch are marked with inch product codes e.g. 8 and 22mm



MODEL DESIGNATION EXAMPLE

Position Number						According to Model Designation Legend
1	2	3	4	5	6	
DTG	B	03	06	1	901	Unidirectional filter drier
DTG	B	03	06	1	901	Solid filter core with 100% 3Å desiccant
DTG	B	03	06	1	901	3 inch ³ internal volume
DTG	B	03	06	1	901	When Pos. 5 is "1": connection size 6mm
DTG	B	03	06	1	901	Solder connection metric
DTG	B	03	06	1	901	Standard product

GENERAL CHARACTERISTICS OF DTG-B FILTER - FLARE CONNECTION

Model	Part Number	Type of Connection	Nominal Volume	Connection	Dimensions & Weight ¹⁾				PED Category
				SAE Flare	ØD	B	A	Weight	
				[cm ³]	[inch]	[mm]	[mm]	[mm]	
DTG-B03 024-901	DTG-30001	flare	49	1/4	45	65	112,0	160	3,3
DTG-B03 034-901	DTG-30002	flare	49	3/8	45	65	125,2	160	3,3
DTG-B03 044-901	DTG-30153	flare	49	1/2	45	65	133,2	160	3,3
DTG-B05 024-901	DTG-30003	flare	82	1/4	68	76	123,0	450	3,3
DTG-B05 034-901	DTG-30004	flare	82	3/8	68	76	136,2	450	3,3
DTG-B08 024-901	DTG-30005	flare	131	1/4	68	98	145,0	550	3,3
DTG-B08 034-901	DTG-30006	flare	131	3/8	68	98	158,2	550	3,3
DTG-B08 044-901	DTG-30007	flare	131	1/2	68	98	166,2	550	3,3
DTG-B16 024-901	DTG-30008	flare	262	1/4	68	118	165,0	660	3,3
DTG-B16 034-901	DTG-30009	flare	262	3/8	68	118	178,2	660	3,3
DTG-B16 044-901	DTG-30010	flare	262	1/2	68	118	186,2	660	3,3
DTG-B16 054-901	DTG-30011	flare	262	5/8	68	118	195,4	660	3,3
DTG-B16 064-901	DTG-30012	flare	262	3/4	68	118	195,4	660	3,3
DTG-B30 034-901	DTG-30013	flare	492	3/8	80	193	253,2	1550	3,3
DTG-B30 044-901	DTG-30014	flare	492	1/2	80	193	261,2	1550	3,3
DTG-B30 054-901	DTG-30015	flare	492	5/8	80	193	270,4	1550	3,3
DTG-B30 064-901	DTG-30016	flare	492	3/4	80	193	270,4	1550	3,3
DTG-B30 074-901	DTG-30017	flare	492	7/8	80	193	283,0	1550	3,3
DTG-B41 044-901	DTG-30018	flare	672	1/2	94	194	262,2	2050	3,3
DTG-B41 054-901	DTG-30019	flare	672	5/8	94	194	271,4	2050	3,3

Note: 1) Dimensions are rounded up to integral mm

DTG/L SERIES Uni-Flow Filter Driers

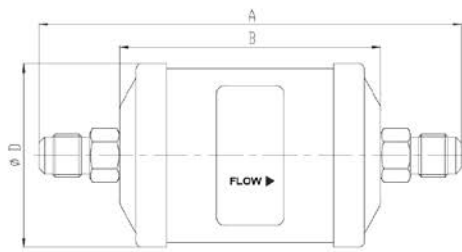

Flare Connection

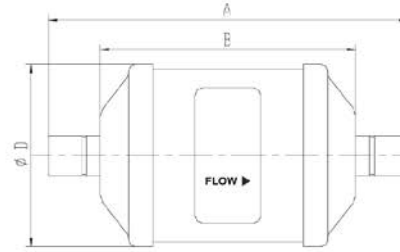

Solder Connection

GENERAL CHARACTERISTICS OF DTG-B FILTER - SOLDER CONNECTION

Model [inch]	Part Number [inch]	Model [mm]	Product Number [mm]	Type of connection	Nominal Volumen [cm ³]	Connection		Dimensions & Weight ¹⁾				PED category
						Solder		D ϕ [mm]	B [mm]	A [mm]	Weight [g]	
						[inch]	[mm]					
DTG-B03 020-901	DTG-30020	DTG-B03 061-901	DTG-30053	solder	49	1/4	6	45	65	103	160	3,3
DTG-B03 250-901	DTG-30021	DTG-B03 250-901	DTG-30021	solder	49	5/16	8	45	65	103	160	3,3
DTG-B03 030-901	DTG-30022	DTG-B03 101-901	DTG-30055	solder	49	3/8	10	45	65	103	160	3,3
DTG-B03 040-901	DTG-30023	DTG-B03 121-901	DTG-30056	solder	49	1/2	12	45	65	113	160	3,3
DTG-B05 020-901	DTG-30024	DTG-B05 061-901	DTG-30057	solder	82	1/4	6	69	76	114	450	3,3
DTG-B05 250-901	DTG-30025	DTG-B05 250-901	DTG-30025	solder	82	5/16	8	69	76	114	450	3,3
DTG-B05 030-901	DTG-30026	DTG-B05 101-901	DTG-30059	solder	82	3/8	10	69	76	114	450	3,3
DTG-B05 040-901	DTG-30027	DTG-B05 121-901	DTG-30060	solder	82	1/2	12	69	76	124	450	3,3
DTG-B05 050-901	DTG-30028	DTG-B05 161-901	DTG30054	solder	82	5/8	16	69	76	124	450	3,3
DTG-B08 020-901	DTG-30029	DTG-B08 061-901	DTG-30061	solder	131	1/4	6	69	98	136	550	3,3
DTG-B08 250-901	DTG-30030	DTG-B08 250-901	DTG-30030	solder	131	5/16	8	69	98	136	550	3,3
DTG-B08 030-901	DTG-30031	DTG-B08 101-901	DTG-30063	solder	131	3/8	10	69	98	136	550	3,3
DTG-B08 040-901	DTG-30032	DTG-B08 121-901	DTG-30064	solder	131	1/2	12	69	98	146	550	3,3
DTG-B08 050-901	DTG-30033	DTG-B08 161-901	DTG-30062	solder	131	5/8	16	69	98	146	550	3,3
DTG-B16 020-901	DTG-30034	DTG-B16 061-901	DTG-30065	solder	262	1/4	6	69	118	156	660	3,3
DTG-B16 250-901	DTG-30035	DTG-B16 250-901	DTG-30035	solder	262	5/16	8	69	118	156	660	3,3
DTG-B16 030-901	DTG-30036	DTG-B16 101-901	DTG-30067	solder	262	3/8	10	69	118	156	660	3,3
DTG-B16 040-901	DTG-30037	DTG-B16 121-901	DTG-30068	solder	262	1/2	12	69	118	166	660	3,3
DTG-B16 050-901	DTG-30038	DTG-B16 161-901	DTG-30066	solder	262	5/8	16	69	118	166	660	3,3
DTG-B16 060-901	DTG-30039	-	-	solder	262	3/4	-	69	118	178	660	3,3
DTG-B16 070-901	DTG-30040	DTG-B16 070-901	DTG-30040	solder	262	7/8	22	69	118	178	660	3,3
DTG-B30 030-901	DTG-30041	DTG-B30 101-901	DTG-30069	solder	492	3/8	10	81	193	231	1550	3,3
DTG-B30 040-901	DTG-30042	DTG-B30 121-901	DTG-30070	solder	492	1/2	12	81	193	241	1550	3,3
DTG-B30 050-901	DTG-30043	DTG-B30 161-901	DTG-30075	solder	492	5/8	16	81	193	241	1550	3,3
DTG-B30 060-901	DTG-30044	-	-	solder	492	3/4	-	81	193	253	1550	3,3



GENERAL CHARACTERISTICS OF DTG-B FILTER - SOLDER CONNECTION

Model [inch]	Part Number [inch]	Model [mm]	Product Number [mm]	Type of connection	Nominal Volume [cm ³]	Connection		Dimensions & Weight ¹⁾				PED category
						Solder		DØ [mm]	B [mm]	A [mm]	Weight [g]	
						[inch]	[mm]					
DTG-B30 070-901	DTG-30045	DTG-B30 070-901	DTG-30045	solder	492	7/8	22	81	193	253	1550	3,3
DTG-B30 090-901	DTG-30046	DTG-B30 281-901	DTG-30071	solder	492	1 1/8	28	81	193	263	1550	3,3
DTG-B41 040-901	DTG-30047	DTG-B41 121-901	DTG-30072	solder	672	1/2	12	94	194	242	2050	3,3
DTG-B41 050-901	DTG-30048	DTG-B41 161-901	DTG-30058	solder	672	5/8	16	94	194	242	2050	3,3
DTG-B41 070-901	DTG-30049	DTG-B41 070-901	DTG-30049	solder	672	7/8	22	94	194	254	2050	3,3
DTG-B41 090-901	DTG-30050	DTG-B41 281-901	DTG-30073	solder	672	1 1/8	28	94	194	264	2050	3,3
DTG-B75 070-901	DTG-30051	DTG-B75 070-901	DTG-30051	solder	1229	7/8	22	94	333	393	3400	3,3
DTG-B75 090-901	DTG-30052	DTG-B75 281-901	DTG-30074	solder	1229	1 1/8	28	94	333	403	3400	3,3

Note: 1) Dimensions are rounded up to integral mm

GENERAL CHARACTERISTICS OF DTG-F FILTER - FLARE CONNECTION

Model ¹⁾	Part Number	Type of Connection	Nominal Volume	Connection		Dimensions & Weight ²⁾				PED Category
				SAE Flare	DØ	B	A	Weight		
DTG-F03 024-901	DTG-30078	flare	49	1/4	45	65	112,0	160	3,3	
DTG-F03 034-901	DTG-30079	flare	49	3/8	45	65	125,2	160	3,3	
DTG-F03 044-901	DTG-30154	flare	49	1/2	45	65	133,2	160	3,3	
DTG-F05 024-901	DTG-30080	flare	82	1/4	69	76	123,0	450	3,3	
DTG-F05 034-901	DTG-30081	flare	82	3/8	69	76	136,2	450	3,3	
DTG-F08 024-901	DTG-30082	flare	131	1/4	69	98	145,0	550	3,3	
DTG-F08 034-901	DTG-30083	flare	131	3/8	69	98	158,2	550	3,3	
DTG-F08 044-901	DTG-30084	flare	131	1/2	69	98	166,2	550	3,3	
DTG-F16 024-901	DTG-30085	flare	262	1/4	69	118	165,0	660	3,3	
DTG-F16 034-901	DTG-30086	flare	262	3/8	69	118	178,2	660	3,3	
DTG-F16 044-901	DTG-30087	flare	262	1/2	69	118	186,2	660	3,3	
DTG-F16 054-901	DTG-30088	flare	262	5/8	69	118	195,4	660	3,3	
DTG-F16 064-901	DTG-30089	flare	262	3/4	69	118	195,4	660	3,3	
DTG-F30 034-901	DTG-30090	flare	492	3/8	81	193	253,2	1550	3,3	



GENERAL CHARACTERISTICS OF DTG-F FILTER - FLARE CONNECTION

Model ¹⁾	Part Number	Type of Connection	Nominal Volume	Connection	Dimensions & Weight ²⁾				PED Category
				SAE Flare	DØ	B	A	Weight	
			[cm ³]	[inch]	[mm]	[mm]	[mm]	[g]	
DTG-F30 044-901	DTG-30091	flare	492	1/2	81	193	261,2	1550	3,3
DTG-F30 054-901	DTG-30092	flare	492	5/8	81	193	270,4	1550	3,3
DTG-F30 064-901	DTG-30093	flare	492	3/4	81	193	270,4	1550	3,3
DTG-F30 074-901	DTG-30094	flare	492	7/8	81	193	283,0	1550	3,3
DTG-F41 044-901	DTG-30095	flare	672	1/2	94	194	262,2	2050	3,3
DTG-F41 054-901	DTG-30096	flare	672	5/8	94	194	271,4	2050	3,3

Note: 1) Delivery time on request
2) Dimensions are rounded up to integral mm

GENERAL CHARACTERISTICS OF DTG-F FILTER - SOLDER CONNECTION

Model ¹⁾ [inch]	Part Number [inch]	Model ¹⁾ [mm]	Product Number [mm]	Type of connection	Nominal Volumen	Connection	Dimensions & Weight ²⁾				PED category	
						Solder	DØ	B	A	Weight		
DTG-F03 020-901	DTG-30097	DTG-F03 061-901	DTG-30130	solder	49	1/4	6	45	65	103	160	3,3
DTG-F03 250-901	DTG-30098	DTG-F03 250-901	DTG-30098	solder	49	5/16	8	45	65	103	160	3,3
DTG-F03 030-901	DTG-30099	DTG-F03 101-901	DTG-30131	solder	49	3/8	10	45	65	103	160	3,3
DTG-F03 040-901	DTG-30100	DTG-F03 121-901	DTG-30132	solder	49	1/2	12	45	65	113	160	3,3
DTG-F05 020-901	DTG-30101	DTG-F05 061-901	DTG-30133	solder	82	1/4	6	69	76	114	450	3,3
DTG-F05 250-901	DTG-30102	DTG-F05 250-901	DTG-30102	solder	82	5/16	8	69	76	114	450	3,3
DTG-F05 030-901	DTG-30103	DTG-F05 101-901	DTG-30134	solder	82	3/8	10	69	76	114	450	3,3
DTG-F05 040-901	DTG-30104	DTG-F051 21-901	DTG-30135	solder	82	1/2	12	69	76	124	450	3,3
DTG-F05 050-901	DTG-30105	DTG-F05 1 61-901	DTG-30136	solder	82	5/8	16	69	76	124	450	3,3
DTG-F08 020-901	DTG-30106	DTG-F08 061-901	DTG-30137	solder	131	1/4	6	69	98	136	550	3,3
DTG-F08 250-901	DTG-30107	DTG-F08 250-901	DTG-30107	solder	131	5/16	8	69	98	136	550	3,3
DTG-F08 030-901	DTG-30108	DTG-F08 101-901	DTG-30138	solder	131	3/8	10	69	98	136	550	3,3
DTG-F08 040-901	DTG-30109	DTG-F08 121-901	DTG-30139	solder	131	1/2	12	69	98	146	550	3,3
DTG-F08 050-901	DTG-30110	DTG-F08 161-901	DTG-30140	solder	131	5/8	16	69	98	146	550	3,3
DTG-F16 020-901	DTG-30111	DTG-F16 061-901	DTG-30141	solder	262	1/4	6	69	118	156	660	3,3



GENERAL CHARACTERISTICS OF DTG-F FILTER - SOLDER CONNECTION

Model ¹⁾ [inch]	Part Number [inch]	Model ¹⁾ [mm]	Product Number [mm]	Type pf connection	Nominal Volumen [cm ³]	Connection		Dimensions & Weight ²⁾					PED category
						Solder		DØ [mm]	B [mm]	A [mm]	Weight [g]		
						[inch]	[mm]						
DTG-F16 250-901	DTG-30112	DTG-F16 250-901	DTG-30112	solder	262	5/16	8	69	118	156	660	3,3	
DTG-F16 030-901	DTG-30113	DTG-F16 101-901	DTG-30142	solder	262	3/8	10	69	118	156	660	3,3	
DTG-F16 040-901	DTG-30114	DTG-F16 121-901	DTG-30143	solder	262	1/2	12	69	118	166	660	3,3	
DTG-F16 050-901	DTG-30115	DTG-F16 161-901	DTG-30144	solder	262	5/8	16	69	118	166	660	3,3	
DTG-F16 060-901	DTG-30116	-	-	solder	262	3/4	-	69	118	178	660	3,3	
DTG-F16 070-901	DTG-30117	DTG-F16 070-901	DTG-30117	solder	262	7/8	22	69	118	178	660	3,3	
DTG-F30 030-901	DTG-30118	DTG-F30 101-901	DTG-30145	solder	492	3/8	10	81	193	231	1550	3,3	
DTG-F30 040-901	DTG-30119	DTG-F30 121-901	DTG-30146	solder	492	1/2	12	81	193	241	1550	3,3	
DTG-F30 050-901	DTG-30120	DTG-F30 161-901	DTG-30147	solder	492	5/8	16	81	193	241	1550	3,3	
DTG-F30 060-901	DTG-30121	-	-	solder	492	3/4	-	81	193	253	1550	3,3	
DTG-F30 070-901	DTG-30122	DTG-F30 070-901	DTG-30122	solder	492	7/8	22	81	193	253	1550	3,3	
DTG-F30 090-901	DTG-30123	DTG-F30 281-901	DTG-30148	solder	492	1 1/8	28	81	193	263	1550	3,3	
DTG-F41 040-901	DTG-30124	DTG-F41 121-901	DTG-30149	solder	672	1/2	12	94	194	242	2050	3,3	
DTG-F41 050-901	DTG-30125	DTG-F41 161-901	DTG-30150	solder	672	5/8	16	94	194	242	2050	3,3	
DTG-F41 070-901	DTG-30126	DTG-F41 070-901	DTG-30126	solder	672	7/8	22	94	194	254	2050	3,3	
DTG-F41 090-901	DTG-30127	DTG-F41 281-901	DTG-30151	solder	672	1 1/8	28	94	194	264	2050	3,3	
DTG-F75 070-901	DTG-30128	DTG-F75 070-901	DTG-30128	solder	1229	7/8	22	94	333	393	3400	3,3	
DTG-F75 090-901	DTG-30129	DTG-F75 281-901	DTG-30152	solder	1229	1 1/8	28	94	333	403	3400	3,3	

Note: 1) Delivery time on request
2) Dimensions are rounded up to integral mm

SELECTION TABLE

Model	Capacity [kW]					Moisture Absorption (gram H ₂ O)							
	R134a	R404A	R22	R407C	R410A	R134a		R404A		R407C		R22	
		R507A				75°F	125°F	75°F	125°F	75°F	125°F		
						23,9°C	51,7°C	23,9°C	51,7°C	23,9°C	51,7°C	23,9°C	51,7°C
	DTG-B03 020-901	7,7	6,7	8,1	8,1	8,1	4,2	3,8	5,7	3,4	3,4	3,1	3,7
DTG-B03 024-901	7,7	6,7	8,1	8,1	8,1	4,2	3,8	5,7	3,4	3,4	3,1	3,7	3,4
DTG-B03 250-901	9,5	6,7	9,5	9,5	9,8	4,2	3,8	5,7	3,4	3,4	3,1	3,7	3,4
DTG-B03 030-901	14,4	10,6	14,8	14,8	14,8	4,2	3,8	5,7	3,4	3,4	3,1	3,7	3,4
DTG-B03 034-901	14,4	10,6	14,8	14,8	14,8	4,2	3,8	5,7	3,4	3,4	3,1	3,7	3,4

DTG/L SERIES Uni-Flow Filter Driers



SELECTION TABLE

Model	Capacity [kW]					Moisture Absorption (gram H ₂ O)							
	R134a	R404A	R22	R407C	R410A	R134a		R404A		R407C		R22	
		R507A				75°F	125°F	75°F	125°F	75°F	125°F	75°F	125°F
						23,9°C	51,7°C	23,9°C	51,7°C	23,9°C	51,7°C	23,9°C	51,7°C
DTG-B03 040-901	24,6	17,2	25,0	24,6	25,0	4,2	3,8	5,7	3,4	3,4	3,1	3,7	3,4
DTG-B03 044-901	24,6	17,2	25,0	24,6	25,0	4,2	3,8	5,7	3,4	3,4	3,1	3,7	3,4
DTG-B05 020-901	8,4	6,0	8,4	8,4	8,4	11,6	10,9	17,7	10,2	10,9	9,5	11,4	9,7
DTG-B05 024-901	8,4	6,0	8,4	8,4	8,4	11,6	10,9	17,7	10,2	10,9	9,5	11,4	9,7
DTG-B05 250-901	10,9	7,4	10,9	10,9	11,3	11,6	10,9	17,7	10,2	10,9	9,5	11,4	9,7
DTG-B05 030-901	23,9	16,9	24,3	23,9	24,6	11,6	10,9	17,7	10,2	10,9	9,5	11,4	9,7
DTG-B05 034-901	23,9	16,9	24,3	23,9	24,6	11,6	10,9	17,7	10,2	10,9	9,5	11,4	9,7
DTG-B05 040-901	25,3	17,9	25,7	25,7	26,0	11,6	10,9	17,7	10,2	10,9	9,5	11,4	9,7
DTG-B05 050-901	34,8	24,6	35,5	35,2	35,9	11,6	10,9	17,7	10,2	10,9	9,5	11,4	9,7
DTG-B08 020-901	8,4	6,0	8,4	8,4	8,4	14,8	14,2	23,7	19,8	14,8	13,0	15,5	13,1
DTG-B08 024-901	8,4	6,0	8,4	8,4	8,4	14,8	14,2	23,7	19,8	14,8	13,0	15,5	13,1
DTG-B08 250-901	11,6	8,1	12,0	11,6	12,0	14,8	14,2	23,7	19,8	14,8	13,0	15,5	13,1
DTG-B08 030-901	25,0	17,6	25,3	25,0	25,7	14,8	14,2	23,7	19,8	14,8	13,0	15,5	13,1
DTG-B08 034-901	25,0	17,6	25,3	25,0	25,7	14,8	14,2	23,7	19,8	14,8	13,0	15,5	13,1
DTG-B08 040-901	30,6	21,5	31,3	30,9	31,7	14,8	14,2	23,7	19,8	14,8	13,0	15,5	13,1
DTG-B08 044-901	30,6	21,5	31,3	30,9	31,7	14,8	14,2	23,7	19,8	14,8	13,0	15,5	13,1
DTG-B08 050-901	44,7	31,7	45,7	45,4	46,1	14,8	14,2	23,7	19,8	14,8	13,0	15,5	13,1
DTG-B16 020-901	10,9	7,7	11,3	10,9	11,3	20,6	19,5	33,2	18,3	20,6	17,6	20,9	17,7
DTG-B16 024-901	10,9	7,7	11,3	10,9	11,3	20,6	19,5	33,2	18,3	20,6	17,6	20,9	17,7
DTG-B16 250-901	11,6	8,1	12,0	11,6	12,0	20,6	19,5	33,2	18,3	20,6	17,6	20,9	17,7
DTG-B16 030-901	25,7	17,9	26,0	26,0	26,4	20,6	19,5	33,2	18,3	20,6	17,6	20,9	17,7
DTG-B16 034-901	25,7	17,9	26,0	26,0	26,4	20,6	19,5	33,2	18,3	20,6	17,6	20,9	17,7
DTG-B16 040-901	32,4	22,9	33,1	32,7	33,8	20,6	19,5	33,2	18,3	20,6	17,6	20,9	17,7
DTG-B16 044-901	32,4	22,9	33,1	32,7	33,8	20,6	19,5	33,2	18,3	20,6	17,6	20,9	17,7
DTG-B16 050-901	43,3	30,6	43,6	43,6	44,3	20,6	19,5	33,2	18,3	20,6	17,6	20,9	17,7
DTG-B16 054-901	43,3	30,6	43,6	43,6	44,3	20,6	19,5	33,2	18,3	20,6	17,6	20,9	17,7
DTG-B16 060-901	46,4	32,7	47,1	46,8	47,8	20,6	19,5	33,2	18,3	20,6	17,6	20,9	17,7
DTG-B16 064-901	46,4	32,7	47,1	46,8	47,8	20,6	19,5	33,2	18,3	20,6	17,6	20,9	17,7
DTG-B16 070-901	47,1	33,4	48,2	47,8	48,5	20,6	19,5	33,2	18,3	20,6	17,6	20,9	17,7
DTG-B30 030-901	25,7	17,9	26,0	26,0	26,4	51,4	48,7	83,4	51,4	51,3	43,7	52,1	44,1
DTG-B30 034-901	25,7	17,9	26,0	26,0	26,4	51,4	48,7	83,4	51,4	51,3	43,7	52,1	44,1
DTG-B30 040-901	33,1	23,2	33,8	33,4	34,1	51,4	48,7	83,4	51,4	51,3	43,7	52,1	44,1
DTG-B30 044-901	33,1	23,2	33,8	33,4	34,1	51,4	48,7	83,4	51,4	51,3	43,7	52,1	44,1
DTG-B30 050-901	45,7	32,0	46,4	46,1	46,8	51,4	48,7	83,4	51,4	51,3	43,7	52,1	44,1
DTG-B30 054-901	45,7	32,0	46,4	46,1	46,8	51,4	48,7	83,4	51,4	51,3	43,7	52,1	44,1
DTG-B30 060-901	62,6	44,0	63,7	63,3	64,4	51,4	48,7	83,4	51,4	51,3	43,7	52,1	44,1
DTG-B30 064-901	62,6	44,0	63,7	63,3	64,4	51,4	48,7	83,4	51,4	51,3	43,7	52,1	44,1
DTG-B30 070-901	63,0	44,3	64,0	63,7	64,7	51,4	48,7	83,4	51,4	51,3	43,7	52,1	44,1

DTG/L SERIES Uni-Flow Filter Driers



SELECTION TABLE

Model	Capacity [kW]					Moisture Absorption (gram H ₂ O)							
	R134a	R404A	R22	R407C	R410A	R134a		R404A		R407C		R22	
		R507A				75°F	125°F	75°F	125°F	75°F	125°F	75°F	125°F
						23,9°C	51,7°C	23,9°C	51,7°C	23,9°C	51,7°C	23,9°C	51,7°C
DTG-B30 074-901	63,0	44,3	64,0	63,7	64,7	51,4	48,7	83,4	51,4	51,3	43,7	52,1	44,1
DTG-B30 090-901	70,7	52,1	75,3	74,6	76,0	51,4	48,7	83,4	51,4	51,3	43,7	52,1	44,1
DTG-B41 040-901	35,2	24,6	35,9	35,5	36,2	63,7	59,7	103,5	55,7	63,7	58,9	70,2	59,4
DTG-B41 044-901	35,2	24,6	35,9	35,5	36,2	63,7	59,7	103,5	55,7	63,7	58,9	70,2	59,4
DTG-B41 050-901	60,8	42,9	61,9	61,5	62,6	63,7	59,7	103,5	55,7	63,7	58,9	70,2	59,4
DTG-B41 054-901	60,8	42,9	61,9	61,5	62,6	63,7	59,7	103,5	55,7	63,7	58,9	70,2	59,4
DTG-B41 070-901	90,4	63,7	91,8	91,4	92,8	63,7	59,7	103,5	55,7	63,7	58,9	70,2	59,4
DTG-B41 090-901	92,1	64,7	93,6	92,8	94,6	63,7	59,7	103,5	55,7	63,7	58,9	70,2	59,4
DTG-B75 070-901	91,4	64,0	92,8	91,8	93,9	123,3	115,6	200,3	107,9	123,3	114,0	135,8	114,9
DTG-B75 090-901	95,3	67,2	97,1	96,4	98,1	123,3	115,6	200,3	107,9	123,3	114,0	135,8	114,9

Note: The above data is based on filter driers with inch connections and clean system at ideal conditions; with impurities accumulated in the filter, the capacity may decrease.

SELECTION FORMULAS

Filter Driers for liquid line are manufactured in compliance with ARI Standard 710. Maximum flow rate of liquid refrigerant at a differential pressure of 0,07bar (1psi) is indicated by kW (ton) which is based on the temperature of liquid refrigerant 30°C (86°F), the evaporating temperature of -15°C (5°F) and the following mass flow:

- 0,40 kg/min/kW (3.1 lb/min/ton) R134a
- 0,53 kg/min/kW (4.1 lb/min/ton) R404A, R507A
- 0,39 kg/min/kW (3.0 lb/min/ton) R22, R407C
- 0,36 kg/min/kW (2.8 lb/min/ton) R410A

Note: Data on water absorption is based on the following EPD (method: ASHRAE Standard 63.1):

- 60ppm R22
- 50ppm R134a
- 50ppm R404A
- 50ppm R407C
- 50ppm R410A
- 50ppm R507A

SANHUA is the world's largest producer of Micro-Channel Heat Exchangers for Stationary HVAC&R application

**SANHUA DELIVERS
OVER 1,300,000 MCHE
CONDENSERS (CO & HP)
AND EVAPORATORS HELPING
TO IMPROVE SYSTEM
EFFICIENCY BY UP TO 30%**

**DISCOVER
WHY**

www.sanhuaeurope.com



- ✓ Improves efficiency by **30%**
- ✓ Refrigerant Charge Reduction by **30%** *Environmental Friendly*
- ✓ MCH is lighter in weight, smaller in volume *Compact Design*

 **SANHUA**

CHILLING *IDEAS* WORLDWIDE

SANHUA INTERNATIONAL EUROPE
info@sanhuaeurope.com

Bi-Flow Filter Driers

The filter driers of series STG are used in refrigeration system with bidirectional flow to absorb moisture and acid in the system and to filter out the impurities.



FEATURES

- HIGH EFFICIENT IN MOISTURE ABSORPTION, FILTERING IMPURITY, ACID, PAINT REMAINS AND MUD REMOVAL
- HYBRID DESICCANT
- DURABLE AND SOLID FILTER CORES
- FILTERING FINENESS: 20µm
- CORROSION RESISTANT PAINTING CAN SURVIVE SALT SPRAY TEST OF 500 HOURS
- CONNECTION TYPE: FLARE OR SOLDER

GENERAL SPECIFICATIONS

- Applicable for all common HCFC and HFC refrigerants such as: R22, R134a, R404A, R407C, R410A, R507A ...
- Ambient temperature min./max.: -30°C / +55°C
- Medium temperature TS min./max.: -30°C / +120°C
- Max. operating pressure PS: 4,83 MPa (48,3 bar)
- Installation position: preferably installed in liquid line
- Certifications: UL/CSA and PED declaration

TECHNICAL PARAMETERS *Desiccant Selection Table*

	Medium Type	80% 3Å Desiccant and 20% Active Alumina	100% 3Å Desiccant
Refrigerant ¹	HFC	applicable	applicable
	HCFC	applicable	applicable
	CFC	applicable	not applicable
Oil ²	Mineral oil or AB	applicable	applicable
	Pure POE or PAG	applicable	applicable
	POE or PAG with additive	not applicable	applicable

Note: 1) For CFC system, usage of core with alumina is recommended as a strong capability to absorb acid may be needed
 2) When the systems use oil with additive, it is not recommended to use a core with alumina.

STG SERIES

Bi-Flow Filter Driers



Model Designation Legend

1	Product Code	Filter Drier Series	
	STG	Indicates bidirectional filter drier	
2	Filter Core	Structure and Material	
	A	Loos core, 100%3Å desiccant	
	B	Solid core, 100%3Å desiccant	
	E	Loos core, 80% 3Å desiccant and 20% active alumina	
	F	Solid core, 80% 3Å desiccant and 20% active alumina	
3	Internal Volume	Expressed in [inch³]	Expressed in [cm³]
	03	3	49
	05	5	82
	08	8	131
	16	16	262
	30	30	492
4	Connection Size	Pos. 5 shows "0": Solder [inch]	Pos. 5 shows "4": SAE Flare [inch]
	02	1/4	1/4
	25	5/16	-
	03	3/8	3/8
	04	1/2	1/2
	05	5/8	5/8
	06	3/4	3/4
	07	7/8	7/8
	09	1 1/8	-
	Connection Size	Pos. 5 shows "1": Solder [mm]	
	06	6	
	(08) *	(5/16" version can be used e.g. STG-B08 250)	
	10	10	
	12	12	
16	16		
(22) *	(7/8" version can be used e.g. STG-B16 070)		
28	28		
5	Pipe Connection	Type	
	0	Solder with inch connections	
	1 *	Solder with metric connections	
	4	SAE flare connections	
6	Version Number	Description	
	901	Standard product	

Note: * Solder connections which fit to metric and inch are marked with inch product codes e.g. 8 and 22mm



MODEL DESIGNATION EXAMPLE

Position Number						According to Model Designation Legend
1	2	3	4	5	6	
STG	B	05	06	1	901	Bidirectional filter drier
STG	B	05	06	1	901	Solid filter core with 100% 3Å desiccant
STG	B	05	06	1	901	5 inch ³ internal volume
STG	B	05	06	1	901	When Pos. 5 is "1": connection size 6mm
STG	B	05	06	1	901	Solder connection metric
STG	B	05	06	1	901	Standard product

GENERAL CHARACTERISTICS OF STG-B FILTER - FLARE CONNECTION

Model	Part Number	Type of Connection	Nominal Volume	Connection	Dimensions & Weight ¹⁾				PED Category
				SAE Flare	ØD	B	A	Weight	
				[cm ³]	[inch]	[mm]	[mm]	[mm]	
STG-B05 024-901	STG-31001	flare	82	1/4	69	76	123	450	3,3
STG-B05 034-901	STG-31002	flare	82	3/8	69	76	137	450	3,3
STG-B05 044-901	STG-31003	flare	82	1/2	69	76	145	450	3,3
STG-B08 024-901	STG-31004	flare	131	1/4	69	98	145	580	3,3
STG-B08 034-901	STG-31005	flare	131	3/8	69	98	159	580	3,3
STG-B08 044-901	STG-31006	flare	131	1/2	69	98	167	580	3,3
STG-B16 034-901	STG-31007	flare	262	3/8	81	118	179	900	3,3
STG-B16 044-901	STG-31008	flare	262	1/2	81	118	187	900	3,3
STG-B16 054-901	STG-31009	flare	262	5/8	81	118	196	900	3,3
STG-B30 034-901	STG-31010	flare	492	3/8	81	193	254	1700	3,3
STG-B30 044-901	STG-31011	flare	492	1/2	81	193	262	1700	3,3
STG-B30 054-901	STG-31012	flare	492	5/8	81	193	271	1700	3,3
STG-B30 064-901	STG-31013	flare	492	3/4	81	193	271	1700	3,3

Note: 1) Dimensions are rounded up to integral mm

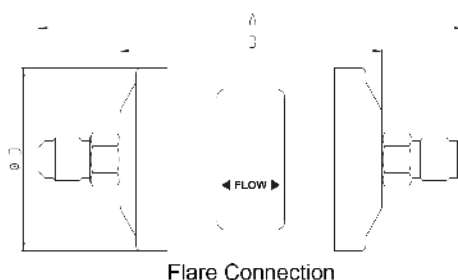



GENERAL CHARACTERISTICS OF STG-B FILTER - SOLDER CONNECTION

Model [inch]	Part Number [inch]	Model [mm]	Part Number [mm]	Type pf connection	Nominal Volumen [cm ³]	Connection		Dimensions & Weight ¹⁾				PED category
						Solder		DØ [mm]	B [mm]	A [mm]	Weight [g]	
						[inch]	[mm]					
STG-B05 020-901	STG-31014	STG-B05 061-901	STG-31031	solder	82	1/4	6	69	76	114	450	3,3
STG-B05 030-901	STG-31015	STG-B05 101-901	STG-31032	solder	82	3/8	10	69	76	114	450	3,3
STG-B05 040-901	STG-31016	STG-B05 121-901	STG-31033	solder	82	1/2	12	69	76	124	450	3,3
STG-B08 020-901	STG-31017	STG-B08 061-901	STG-31034	solder	131	1/4	6	69	98	136	580	3,3
STG-B08 250-901	STG-31018	STG-B08 250-901	STG-31018	solder	131	5/16	8	69	98	136	580	3,3
STG-B08 030-901	STG-31019	STG-B08 101-901	STG-31035	solder	131	3/8	10	69	98	136	580	3,3
STG-B08 040-901	STG-31020	STG-B08 121-901	STG-31036	solder	131	1/2	12	69	98	146	580	3,3
STG-B16 030-901	STG-31021	STG-B16 101-901	STG-31037	solder	262	3/8	10	81	118	156	900	3,3
STG-B16 040-901	STG-31022	STG-B16 121-901	STG-31038	solder	262	1/2	12	81	118	166	900	3,3
STG-B16 050-901	STG-31023	STG-B16 161-901	STG-31087	solder	262	5/8	16	81	118	166	900	3,3
STG-B16 070-901	STG-31024	STG-B16 070-901	STG-31024	solder	262	7/8	22	81	118	178	900	3,3
STG-B30 030-901	STG-31025	STG-B30 101-901	STG-31039	solder	492	3/8	10	81	193	231	1700	3,3
STG-B30 040-901	STG-31026	STG-B30 121-901	STG-31040	solder	492	1/2	12	81	193	241	1700	3,3
STG-B30 050-901	STG-31027	STG-B30 161-901	STG-31088	solder	492	5/8	16	81	193	241	1700	3,3
STG-B30 060-901	STG-31028	-	-	solder	492	3/4	-	81	193	253	1700	3,3
STG-B30 070-901	STG-31029	STG-B30 070-901	STG-31029	solder	492	7/8	22	81	193	253	1700	3,3
STG-B30 090-901	STG-31030	STG-B30 281-901	STG-31043	solder	492	1 1/8	28	81	193	263	1700	3,3

Note: 1) Dimensions are rounded up to integral mm

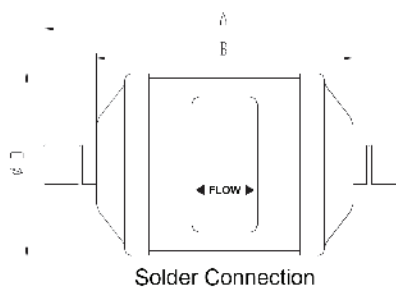



GENERAL CHARACTERISTICS OF STG-F FILTER - FLARE CONNECTION

Model ¹⁾	Part Number	Type of Connection	Nominal Volume	Connection		Dimensions & Weight ²⁾				PED Category
				SAE Flare		ØD	B	A	Weight	
			[cm ³]	[inch]	[mm]	[mm]	[mm]	[g]		
STG-F05 024-901	STG-31044	flare	82	1/4	69	76	123	450	3,3	
STG-F05 034-901	STG-31045	flare	82	3/8	69	76	137	450	3,3	
STG-F05 044-901	STG-31046	flare	82	1/2	69	76	145	450	3,3	
STG-F08 024-901	STG-31047	flare	131	1/4	69	98	145	580	3,3	
STG-F08 034-901	STG-31048	flare	131	3/8	69	98	159	580	3,3	
STG-F08 044-901	STG-31049	flare	131	1/2	69	98	167	580	3,3	
STG-F16 034-901	STG-31050	flare	262	3/8	81	118	179	900	3,3	
STG-F16 044-901	STG-31051	flare	262	1/2	81	118	187	900	3,3	
STG-F16 054-901	STG-31052	flare	262	5/8	81	118	196	900	3,3	
STG-F30 034-901	STG-31053	flare	492	3/8	81	193	254	1700	3,3	
STG-F30 044-901	STG-31054	flare	492	1/2	81	193	262	1700	3,3	
STG-F30 054-901	STG-31055	flare	492	5/8	81	193	271	1700	3,3	
STG-F30 064-901	STG-31056	flare	492	3/4	81	193	271	1700	3,3	

Note: 1) Delivery time on request
2) Dimensions are rounded up to integral mm

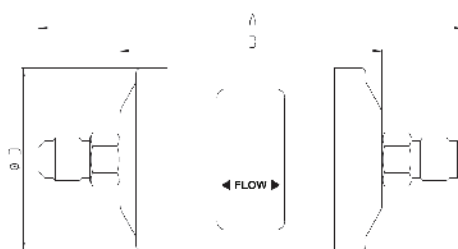

Flare Connection

STG SERIES

Bi-Flow Filter Driers



GENERAL CHARACTERISTICS OF STG-F FILTER - SOLDER CONNECTION

Model ¹⁾ [inch]	Part Number [inch]	Model ¹⁾ [mm]	Part Number [mm]	Type of connection	Nominal Volumen [cm ³]	Connection		Dimensions & Weight ²⁾				PED category
						Solder		D∅ [mm]	B [mm]	A [mm]	Weight [g]	
						[inch]	[mm]					
STG-F05 020-901	STG-31057	STG-F05 061-901	STG-31074	solder	82	1/4	6	69	76	114	450	3,3
STG-F05 030-901	STG-31058	STG-F05 101-901	STG-31075	solder	82	3/8	10	69	76	114	450	3,3
STG-F05 040-901	STG-31059	STG-F05 121-901	STG-31076	solder	82	1/2	12	69	76	124	450	3,3
STG-F08 020-901	STG-31060	STG-F08 061-901	STG-31077	solder	131	1/4	6	69	98	136	580	3,3
STG-F08 250-901	STG-31061	STG-F08 250-901	STG-31061	solder	131	5/16	8	69	98	136	580	3,3
STG-F08 030-901	STG-31062	STG-F08 101-901	STG-31078	solder	131	3/8	10	69	98	136	580	3,3
STG-F08 040-901	STG-31063	STG-F08 121-901	STG-31079	solder	131	1/2	12	69	98	146	580	3,3
STG-F16 030-901	STG-31064	STG-F16 101-901	STG-31080	solder	262	3/8	10	81	118	156	900	3,3
STG-F16 040-901	STG-31065	STG-F16 121-901	STG-31081	solder	262	1/2	12	81	118	166	900	3,3
STG-F16 050-901	STG-31066	STG-F16 161-901	STG-31082	solder	262	5/8	16	81	118	166	900	3,3
STG-F16 070-901	STG-31067	STG-F16 070-901	STG-31067	solder	262	7/8	22	81	118	178	900	3,3
STG-F30 030-901	STG-31068	STG-F30 101-901	STG-31083	solder	492	3/8	10	81	193	231	1700	3,3
STG-F30 040-901	STG-31069	STG-F30 121-901	STG-31084	solder	492	1/2	12	81	193	241	1700	3,3
STG-F30 050-901	STG-31070	STG-F30 161-901	STG-31085	solder	492	5/8	16	81	193	241	1700	3,3
STG-F30 060-901	STG-31071	-	-	solder	492	3/4	-	81	193	253	1700	3,3
STG-F30 070-901	STG-31072	STG-F30 070-901	STG-31072	solder	492	7/8	22	81	193	253	1700	3,3
STG-F30 090-901	STG-31073	STG-F30 281-901	STG-31086	solder	492	1 1/8	28	81	193	263	1700	3,3

Note: 1) Delivery time on request
 2) Dimensions are rounded up to integral mm

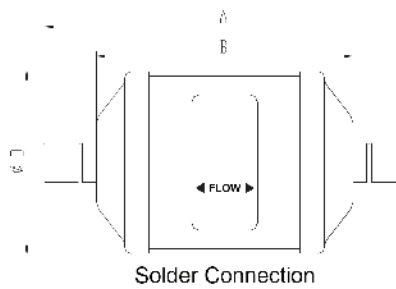

STG SERIES

Bi-Flow Filter Driers



SELECTION TABLE

Model	Capacity [kW] ¹					Moisture Absorption (gram H ₂ O)							
	R134a	R404A	R22	R407C ²	R410A	R134a		R404A		R407C ²		R22	
		R507A				75°F	125°F	75°F	125°F	75°F	125°F	75°F	125°F
						23,9°C	51,7°C	23,9°C	51,7°C	23,9°C	51,7°C	23,9°C	51,7°C
	STG-B05 020-901	7,4	5,3	7,7	7,7	7,7	4,3	4,0	4,1	3,8	3,7	3,4	4,1
STG-B05 024-901	7,4	5,3	7,7	7,7	7,7	4,3	4,0	4,1	3,8	3,7	3,4	4,1	3,7
STG-B05 030-901	16,5	11,6	16,9	16,5	16,9	4,3	4,0	4,1	3,8	3,7	3,4	4,1	3,7
STG-B05 034-901	16,5	11,6	16,9	16,5	16,9	4,3	4,0	4,1	3,8	3,7	3,4	4,1	3,7
STG-B05 040-901	25,0	17,6	25,3	25,0	25,3	4,3	4,0	4,1	3,8	3,7	3,4	4,1	3,7
STG-B05 044-901	25,0	17,6	25,3	25,0	25,3	4,3	4,0	4,1	3,8	3,7	3,4	4,1	3,7
STG-B08 020-901	8,8	6,0	8,8	8,8	8,8	9,8	9,0	9,2	8,6	8,5	7,8	9,2	8,5
STG-B08 024-901	8,8	6,0	8,8	8,8	8,8	9,8	9,0	9,2	8,6	8,5	7,8	9,2	8,5
STG-B08 250-901	15,8	10,9	16,2	15,8	16,2	9,8	9,0	9,2	8,6	8,5	7,8	9,2	8,5
STG-B08 030-901	17,2	12,0	17,6	17,2	17,6	9,8	9,0	9,2	8,6	8,5	7,8	9,2	8,5
STG-B08 034-901	17,2	12,0	17,6	17,2	17,6	9,8	9,0	9,2	8,6	8,5	7,8	9,2	8,5
STG-B08 040-901	25,7	17,9	26,4	26,0	26,4	9,8	9,0	9,2	8,6	8,5	7,8	9,2	8,5
STG-B08 044-901	25,7	17,9	26,4	26,0	26,4	9,8	9,0	9,2	8,6	8,5	7,8	9,2	8,5
STG-B16 030-901	19,7	13,7	20,0	19,7	20,0	17,6	16,3	16,6	15,5	15,2	14,0	16,6	14,2
STG-B16 034-901	19,7	13,7	20,0	19,7	20,0	17,6	16,3	16,6	15,5	15,2	14,0	16,6	14,2
STG-B16 040-901	30,2	21,5	30,9	30,6	30,9	17,6	16,3	16,6	15,5	15,2	14,0	16,6	14,2
STG-B16 044-901	30,2	21,5	30,9	30,6	30,9	17,6	16,3	16,6	15,5	15,2	14,0	16,6	14,2
STG-B16 050-901	34,1	23,9	34,8	34,5	35,2	17,6	16,3	16,6	15,5	15,2	14,0	16,6	14,2
STG-B16 054-901	34,1	23,9	34,8	34,5	35,2	17,6	16,3	16,6	15,5	15,2	14,0	16,6	14,2
STG-B16 070-901	42,2	29,9	42,9	42,6	43,3	17,6	16,3	16,6	15,5	15,2	14,0	16,6	14,2
STG-B30 030-901	25,0	17,6	25,3	25,0	25,7	41,3	38,4	38,9	36,5	35,9	32,9	39,1	33,1
STG-B30 034-901	25,0	17,6	25,3	25,0	25,7	41,3	38,4	38,9	36,5	35,9	32,9	39,1	33,1
STG-B30 040-901	30,9	21,8	31,7	31,7	32,0	41,3	38,4	38,9	36,5	35,9	32,9	39,1	33,1
STG-B30 044-901	30,9	21,8	31,7	31,7	32,0	41,3	38,4	38,9	36,5	35,9	32,9	39,1	33,1
STG-B30 050-901	35,5	25,0	36,2	35,9	36,6	41,3	38,4	38,9	36,5	35,9	32,9	39,1	33,1
STG-B30 054-901	35,5	25,0	36,2	35,9	36,6	41,3	38,4	38,9	36,5	35,9	32,9	39,1	33,1
STG-B30 060-901	39,6	28,1	40,1	39,7	40,4	41,3	38,4	38,9	36,5	35,9	32,9	39,1	33,1
STG-B30 064-901	39,6	28,1	40,1	39,7	40,4	41,3	38,4	38,9	36,5	35,9	32,9	39,1	33,1
STG-B30 070-901	46,4	32,4	47,1	46,8	47,5	41,3	38,4	38,9	36,5	35,9	32,9	39,1	33,1
STG-B30 090-901	54,2	38,0	55,2	54,5	55,6	41,3	38,4	38,9	36,5	35,9	32,9	39,1	33,1

Note: 1) The above data is based on filter driers with inch connections and clean system at ideal conditions; with impurities accumulated in the filter, the capacity may decrease.
 2) R407C data based on dew point conditions

STG SERIES

Bi-Flow Filter Driers



SELECTION FORMULAS

Filter driers for liquid line are manufactured in compliance with ARI Standard 710. Maximum flow rate of liquid refrigerant at a differential pressure of 0,07bar (1psi) is indicated by kW (ton) which is based on the temperature of liquid refrigerant 30°C (86°F), the evaporating temperature of -15°C (5°F) and the following mass flow:

- 0,40 kg/min/kW (3.1 lb/min/ton) R134a
- 0,53 kg/min/kW (4.1 lb/min/ton) R404A, R507A
- 0,39 kg/min/kW (3.0 lb/min/ton) R22, R407C
- 0,36 kg/min/kW (2.8 lb/min/ton) R410A

Note: Data on water absorption is based on the following EPD (method: ASHRAE Standard 63.1):

- 60ppm R22
- 50ppm R134a
- 50ppm R404A
- 50ppm R407C
- 50ppm R410A
- 50ppm R507A



HI I'M SOLY, THE SANHUA SOLENOID VALVE, I CAN HELP YOU TO FIND SANHUA'S BEST SOLUTION FOR YOU



SANHUA



SELECTION TOOL



CROSS REFERENCE TOOL



SANHUA Selection Tool gives you the possibility to identify the best component suitable in our range which covers your system requirement.

DOWNLOAD it and make your system design easy using this intuitive Sanhua Tool.



SANHUA with the collaboration of his dealers and technical team makes you easy to identify our products compared to other components and brands in the market.

Don't forget to double check if our suggestion covers your entire requirements.

Copper Filter Drier

The copper filter driers of series BGQ are used in refrigeration system with unidirectional flow to absorb moisture and acid in the system and to filter out the impurities.



FEATURES

- COMPACT DESIGN AND LOW WEIGHT
- HIGH EFFICIENT IN MOISTURE ABSORPTION AND FILTERING IMPURITY
- HYBRID DESICCANT
- FILTERING FINENESS: 100µM
- CONNECTION TYPE: SOLDER

GENERAL SPECIFICATIONS

- Applicable for all common HCFC, HFC and HC refrigerants such as: R134a, R404A, R407C, R410A, R507A, R600a ...
- Ambient temperature min./max.: -30/+55°C
- Medium temperature TS min./max.: -30°C / +80°C
- Max. operating pressure PS: 4,2 MPa (42 bar)
- Installation position:
 - Liquid line
 - Flow direction corresponds to the arrow
- Certifications: UL/CSA and PED declaration

TECHNICAL PARAMETERS

Model	Part Number	Molec. Sieve Type	Molec. Sieve Weight [g]	Refrigerant
BGQ-A11015-031	BGQ-28001	XH-11	15	R134a, R404A, R407C, R410A, R507A, R600a
BGQ-A11020-011	BGQ-28002	XH-11	20	R134a, R404A, R407C, R410A, R507A, R600a
BGQ-A11030-090	BGQ-28003	XH-9	30	R134a, R600a



DIMENSIONS

Model	Connections				Dimensions [mm]			
	Inlet $\varnothing d_1$		Outlet $\varnothing d_2$		$\varnothing D$	L	L1	L2
	[mm]	Type ¹⁾	[mm]	Type ¹⁾				
BGQ-A11015-031	6,35	$\varnothing d_1$ ID ODF	6,35	$\varnothing d_1$ ID ODF	19,05	135 ± 2	5	5
BGQ-A11020-011	6,5	$\varnothing d_1$ ID ODF	6,35	$\varnothing d_2$ OD ODM	25,4	127 ± 3	8	10
BGQ-A11030-090	9,52	$\varnothing d_1$ ID ODF	9,52	$\varnothing d_2$ OD ODM	25,4	155 ± 3	8	10

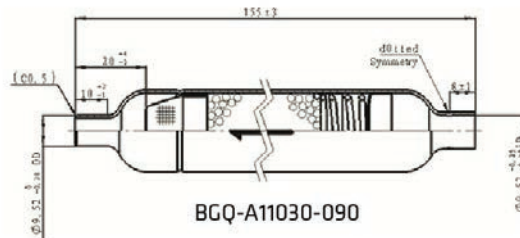
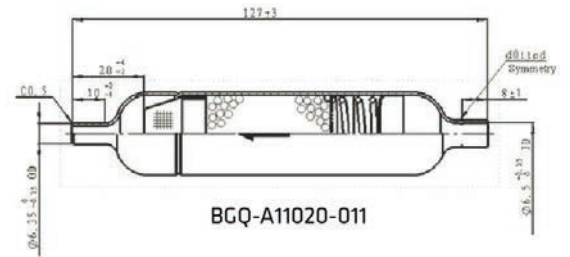
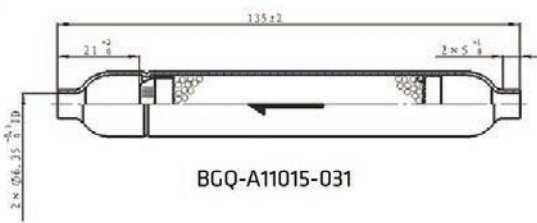

Filter Driers with Replaceable Core

The filter driers with replaceable core (HTG series) are used in liquid line and suction line of refrigerating, freezing and air conditioning system. The filter housing allows to choose different kinds of cores. It's sealed by bottom cover for an easy removal and replacement of core from the bottom. The core holder requires minimum free space to remove the core for replacement.



FEATURES

- HIGH EFFICIENT IN MOISTURE ABSORPTION, FILTERING IMPURITY, ACID, PAINT REMAINS AND MUD REMOVAL
- HYBRID DESICCANT
- DURABLE AND SOLID FILTER CORES
- FILTERING FINENESS: 20µm
- CORROSION RESISTANT PAINTING CAN SURVIVE SALT SPRAY TEST OF 500 HOURS
- CONNECTION TYPE: FLARE OR SOLDER

FEATURES OF FILTER ELEMENT

• SH48-A80 FILTER ELEMENT:

80% 3A DESICCANT AND 20% ACTIVATED ALUMINA, IT PROVIDES A GOOD DESICCATION ABILITY AND AN ACID ABSORPTION CAPABILITY IN A WIDE TEMPERATURE RANGE. THE CORE RESISTANCE IS GUARANTEED WITH HIGH LEVEL OF VIBRATION THANKS TO AN ANTI-SHOCK DESIGN. SUGGESTED INSTALLATION POSITION ON LIQUID LINE

• SH48-A00 FILTER ELEMENT:

100% 3A DESICCANT
IT PROVIDES THE MAXIMUM LEVEL OF DESICCATION ABILITY IN A WIDE TEMPERATURE RANGE. THE CORE RESISTANCE IS GUARANTEED WITH HIGH LEVEL OF VIBRATION THANKS TO AN ANTI-SHOCK DESIGN. SUGGESTED INSTALLATION POSITION ON LIQUID LINE

GENERAL SPECIFICATIONS

- Applicable for all common HCFC and HFC refrigerants such as: R22, R134a, R404A, R407C, R410A, R507A ...
- Ambient temperature min./max.: -30°C / +55°
- Medium temperature TS min./max.: -40°C / +70°C
- Max. operating pressure PS: from 4,5 MPa (45 bar) (see table 1)
- Installation position: preferably installed in liquid line
- Certifications: UL/CSA and PED declaration



MODEL DESIGNATION EXAMPLE

Position Number						According to Model Designation Legend
1	2	3	4	5	6	
HTG	A96	28	1	901		Replaceable core filter drier
HTG	A96	28	1	901		96 inch ³ internal volume
HTG	A96	28	1	901		When Pos. 4 is "1": connection size 28mm
HTG	A96	28	1	901		Solder connection metric
HTG	A96	28	1	901		Standard product

TECHNICAL PARAMETERS

Desiccant Selection Table

	Medium Type	80% 3A desiccant 20% active alumina	100% 3A desiccant
Core Model	-	SH48-A80	SH48-A00
Core Part Number	-	HTG-29102	HTG-29103
Suggested Installation position	-	Liquid Line	Liquid Line
Refrigerant	HFC	Applicable	Suggested
	HCFC	Suggested	Applicable
	CFC	Applicable	Not Applicable
	HC	Applicable	Applicable
Oil	Mineral oil or AB	Suggested	Applicable
	Pure POE or PAG	Applicable	Suggested
	POE or PAG with additive	Not applicable	Applicable

- Note:** 1) For CFC system, usage of core with alumina is recommended as a strong capability to absorb acid may be needed
 2) When the systems use oil with additive, it is not recommended to use a core with alumina.

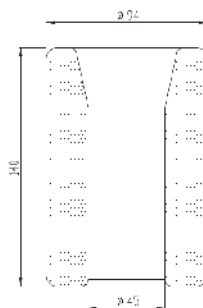

Filter core dimensions

HTG SERIES**Filter Driers with Replaceable Core***Model Designation Legend*

1	Product Code	Filter Drier Series	
	HTG	Indicates replaceable core filter drier	
2	Internal volume	Expressed in inch³	Expressed in cm³
	A48	48	787
	A96	96	1573
	B44	144	2360
	B92	192	3146
3	Connection size	Pos. 4 shows "0": Solder [inch]	
	05	5/8	
	07	7/8	
	09	1 1/8	
	11	1 3/8	
	13	1 5/8	
	17	2 1/8	
	21	2 5/8	
	Connection size	Pos. 4 shows "1": Solder [mm]	
	05	16 - (5/8" version can be used e.g. HTG-A48 050)	
	07	22 - (7/8" version can be used e.g. HTG-A48 070)	
	28	28	
	11	35 - (1 3/8" version can be used e.g. HTG-A48 110)	
	42	42	
17	54 - (2 1/8" version can be used e.g. HTG-A48 170)		
4	Pipe Connection	Type	
	0	Solder with inch connections	
	1 *	Solder with metric connections	
5	Version Number	Description	
	901	Standard product	

Note: * Solder connections which fit to metric and inch are marked with inch product codes e.g. 16, 22, 35 and 54mm



GENERAL CHARACTERISTICS OF FILTER *Table 1*

Series	Model	Part Number	Solder Connections ODF		Number of cores	Dimensions & Weight					Design Pressure (MPa)	PED category
			[in]	[mm]		A	B	L	G	Weight ¹⁾		
						[mm]	[mm]	[mm]	[mm]	[kg]		
HTG A48s	HTG-A48050-901	HTG-29001	5/8	16	1	250	164	170	116	5,1	4,5	Cat. I
	HTG-A48070-901	HTG-29002	7/8	22		249	163	170	116	5,1	4,5	
	HTG-A48090-901	HTG-29003	1 1/8	-		254	168	170	121	5,1	4,5	
	HTG-A48281-901	HTG-29004	-	28		254	168	170	121	5,1	4,5	
	HTG-A48110-901	HTG-29005	1 3/8	35		253	167	170	121	5,1	4,5	
	HTG-A48130-901	HTG-29006	1 5/8	-		272	186	170	141	5,1	4,5	
	HTG-A48421-901	HTG-29007	-	42		272	186	170	141	5,1	4,5	
	HTG-A48170-901	HTG-29008	2 1/8	54		275	182	170	145	5,1	4,5	
HTG A96s	HTG-A96050-901	HTG-29010	5/8	16	2	391	305	310	116	6,2	4,5	
	HTG-A96070-901	HTG-29011	7/8	22		390	304	310	116	6,2	4,5	
	HTG-A96090-901	HTG-29012	1 1/8	-		395	309	310	121	6,2	4,5	
	HTG-A96281-901	HTG-29013	-	28		395	309	310	121	6,2	4,5	
	HTG-A96110-901	HTG-29014	1 3/8	35		394	308	310	121	6,2	4,5	
	HTG-A96130-901	HTG-29015	1 5/8	-		413	327	310	141	6,2	4,5	
	HTG-A96421-901	HTG-29016	-	42		413	327	310	141	6,2	4,5	
	HTG-A96170-901	HTG-29017	2 1/8	54		416	323	310	145	6,2	4,5	
HTG B44s	HTG-A96210-901	HTG-29018	2 5/8	-	418	318	310	149	6,2	4,5		
	HTG-B44050-901	HTG-29019	5/8	16	3	532	446	310	116	7,6	4,5	
	HTG-B44070-901	HTG-29020	7/8	22		531	445	310	116	7,6	4,5	
	HTG-B44090-901	HTG-29021	1 1/8	-		536	450	310	121	7,6	4,5	
	HTG-B44281-901	HTG-29022	-	28		536	450	310	121	7,6	4,5	
	HTG-B44110-901	HTG-29023	1 3/8	35		535	449	310	121	7,6	4,5	
	HTG-B44130-901	HTG-29024	1 5/8	-		554	468	310	141	7,6	4,5	
	HTG-B44421-901	HTG-29025	-	42		554	468	310	141	7,6	4,5	
HTG-B44170-901	HTG-29026	2 1/8	54	557		464	310	145	7,6	4,5		
HTG B92s	HTG-B44210-901	HTG-29027	2 5/8	-	559	459	310	149	7,6	4,5		
	HTG-B92050-901	HTG-29028	5/8	16	4	677	591	310	116	9,1	4,5	
	HTG-B92070-901	HTG-29029	7/8	22		676	590	310	116	9,1	4,5	
	HTG-B92090-901	HTG-29030	1 1/8	-		681	595	310	121	9,1	4,5	
	HTG-B92281-901	HTG-29031	-	28		681	595	310	121	9,1	4,5	
	HTG-B92110-901	HTG-29032	1 3/8	35		680	594	310	121	9,1	4,5	
	HTG-B92130-901	HTG-29033	1 5/8	-		699	613	310	141	9,1	4,5	
	HTG-B92421-901	HTG-29034	-	42		699	613	310	141	9,1	4,5	
HTG-B92170-901	HTG-29035	2 1/8	54	702		609	310	145	9,1	4,5		
	HTG-B92210-901	HTG-29036	2 5/8	-	704	604	310	149	9,1	4,5		

Note: 1) Weight of filter shell (must be added the filter core weight: 0.6 kg)



SELECTION TABLE - WITH CORE SH48-A00 Table 2

Model	Capacity [kW] ¹					Moisture Absorption [gram H ₂ O]							
	R134a	R404A	R22	R407C ²	R410A	R134a		R404A		R407C ²		R22	
		R507A				75°F	125°F	75°F	125°F	75°F	125°F	75°F	125°F
	23,9°C		51,7°C	23,9°C	51,7°C	23,9°C	51,7°C	23,9°C	51,7°C				
HTG-A48050-901	65,5	45,9	67,6	67,6	67,6	67,4	58,1	72,6	59,6	57,0	51,8	62,2	57,0
HTG-A48070-901	104,7	73,5	108,2	108,2	108,2	67,4	58,1	72,6	59,6	57,0	51,8	62,2	57,0
HTG-A48090-901	150,5	105,7	155,4	155,4	155,4	67,4	58,1	72,6	59,6	57,0	51,8	62,2	57,0
HTG-A48281-901	150,5	105,7	155,4	155,4	155,4	67,4	58,1	72,6	59,6	57,0	51,8	62,2	57,0
HTG-A48110-901	202,7	142,5	209,3	209,3	209,3	67,4	58,1	72,6	59,6	57,0	51,8	62,2	57,0
HTG-A48130-901	248,9	174,7	256,6	256,6	256,6	67,4	58,1	72,6	59,6	57,0	51,8	62,2	57,0
HTG-A48421-901	59,9	174,7	256,6	256,6	256,6	67,4	58,1	72,6	59,6	57,0	51,8	62,2	57,0
HTG-A48170-901	353,5	248,2	364,7	364,7	364,7	67,4	58,1	72,6	59,6	57,0	51,8	62,2	57,0
HTG-A48210-901	392,7	276,2	405,7	405,7	405,7	67,4	58,1	72,6	59,6	57,0	51,8	62,2	57,0
HTG-A96050-901	65,5	45,9	67,6	67,6	67,6	134,8	116,1	145,2	119,2	114,0	103,7	124,4	114,0
HTG-A96070-901	104,7	73,5	108,2	108,2	108,2	134,8	116,1	145,2	119,2	114,0	103,7	124,4	114,0
HTG-A96090-901	150,5	105,7	155,4	155,4	155,4	134,8	116,1	145,2	119,2	114,0	103,7	124,4	114,0
HTG-A96281-901	150,5	105,7	155,4	155,4	155,4	134,8	116,1	145,2	119,2	114,0	103,7	124,4	114,0
HTG-A96110-901	202,7	142,5	209,3	209,3	209,3	134,8	116,1	145,2	119,2	114,0	103,7	124,4	114,0
HTG-A96130-901	248,9	174,7	256,6	256,6	256,6	134,8	116,1	145,2	119,2	114,0	103,7	124,4	114,0
HTG-A96421-901	248,9	174,7	256,6	256,6	256,6	134,8	116,1	145,2	119,2	114,0	103,7	124,4	114,0
HTG-A96170-901	353,5	248,2	364,7	364,7	364,7	134,8	116,1	145,2	119,2	114,0	103,7	124,4	114,0
HTG-A96210-901	392,7	276,2	405,7	405,7	405,7	134,8	116,1	145,2	119,2	114,0	103,7	124,4	114,0
HTG-B44050-901	65,5	45,9	67,6	67,6	67,6	202,2	174,3	217,8	178,8	171,0	155,4	186,6	171,0
HTG-B44070-901	104,7	73,5	108,2	108,2	108,2	202,2	174,3	217,8	178,8	171,0	155,4	186,6	171,0
HTG-B44090-901	150,5	105,7	155,4	155,4	155,4	202,2	174,3	217,8	178,8	171,0	155,4	186,6	171,0
HTG-B44281-901	150,5	105,7	155,4	155,4	155,4	202,2	174,3	217,8	178,8	171,0	155,4	186,6	171,0
HTG-B44110-901	202,7	142,5	209,3	209,3	209,3	202,2	174,3	217,8	178,8	171,0	155,4	186,6	171,0
HTG-B44130-901	248,9	174,7	256,6	256,6	256,6	202,2	174,3	217,8	178,8	171,0	155,4	186,6	171,0
HTG-B44421-901	248,9	174,7	256,6	256,6	256,6	202,2	174,3	217,8	178,8	171,0	155,4	186,6	171,0
HTG-B44170-901	353,5	248,2	364,7	364,7	364,7	202,2	174,3	217,8	178,8	171,0	155,4	186,6	171,0
HTG-B44210-901	392,7	276,2	405,7	405,7	405,7	202,2	174,3	217,8	178,8	171,0	155,4	186,6	171,0
HTG-B92050-901	65,5	45,9	67,6	67,6	67,6	269,6	232,4	290,4	238,4	228,0	207,2	248,8	228,0
HTG-B92070-901	104,7	73,5	108,2	108,2	108,2	269,6	232,4	290,4	238,4	228,0	207,2	248,8	228,0
HTG-B92090-901	150,5	105,7	155,4	155,4	155,4	269,6	232,4	290,4	238,4	228,0	207,2	248,8	228,0
HTG-B92281-901	150,5	105,7	155,4	155,4	155,4	269,6	232,4	290,4	238,4	228,0	207,2	248,8	228,0
HTG-B92110-901	202,7	142,5	209,3	209,3	209,3	269,6	232,4	290,4	238,4	228,0	207,2	248,8	228,0
HTG-B92130-901	248,9	174,7	256,6	256,6	256,6	269,6	232,4	290,4	238,4	228,0	207,2	248,8	228,0
HTG-B92421-901	248,9	174,7	256,6	256,6	256,6	269,6	232,4	290,4	238,4	228,0	207,2	248,8	228,0
HTG-B92170-901	353,5	248,2	364,7	364,7	364,7	269,6	232,4	290,4	238,4	228,0	207,2	248,8	228,0
HTG-B92210-901	392,7	276,2	405,7	405,7	405,7	269,6	232,4	290,4	238,4	228,0	207,2	248,8	228,0



SELECTION TABLE - WITH CORE SH48-A80 Table 3

Model	Capacity [kW] ¹					Moisture Absorption [gram H ₂ O]							
	R134a	R404A	R22	R407C ²	R410A	R134a		R404A		R407C ²		R22	
		R507A				75°F	125°F	75°F	125°F	75°F	125°F	75°F	125°F
						23,9°C	51,7°C	23,9°C	51,7°C	23,9°C	51,7°C	23,9°C	51,7°C
	HTG-A48050-901	65,5	45,9	67,6	67,6	67,6	58,0	50,0	61,7	50,7	47,9	43,5	52,9
HTG-A48070-901	104,7	73,5	108,2	108,2	108,2	58,0	50,0	61,7	50,7	47,9	43,5	52,9	48,5
HTG-A48090-901	150,5	105,7	155,4	155,4	155,4	58,0	50,0	61,7	50,7	47,9	43,5	52,9	48,5
HTG-A48281-901	150,5	105,7	155,4	155,4	155,4	58,0	50,0	61,7	50,7	47,9	43,5	52,9	48,5
HTG-A48110-901	202,7	142,5	209,3	209,3	209,3	58,0	50,0	61,7	50,7	47,9	43,5	52,9	48,5
HTG-A48130-901	248,9	174,7	256,6	256,6	256,6	58,0	50,0	61,7	50,7	47,9	43,5	52,9	48,5
HTG-A48421-901	59,9	174,7	256,6	256,6	256,6	58,0	50,0	61,7	50,7	47,9	43,5	52,9	48,5
HTG-A48170-901	353,5	248,2	364,7	364,7	364,7	58,0	50,0	61,7	50,7	47,9	43,5	52,9	48,5
HTG-A48210-901	392,7	276,2	405,7	405,7	405,7	58,0	50,0	61,7	50,7	47,9	43,5	52,9	48,5
HTG-A96050-901	65,5	45,9	67,6	67,6	67,6	115,9	99,8	123,4	101,3	95,8	87,1	105,7	96,9
HTG-A96070-901	104,7	73,5	108,2	108,2	108,2	115,9	99,8	123,4	101,3	95,8	87,1	105,7	96,9
HTG-A96090-901	150,5	105,7	155,4	155,4	155,4	115,9	99,8	123,4	101,3	95,8	87,1	105,7	96,9
HTG-A96281-901	150,5	105,7	155,4	155,4	155,4	115,9	99,8	123,4	101,3	95,8	87,1	105,7	96,9
HTG-A96110-901	202,7	142,5	209,3	209,3	209,3	115,9	99,8	123,4	101,3	95,8	87,1	105,7	96,9
HTG-A96130-901	248,9	174,7	256,6	256,6	256,6	115,9	99,8	123,4	101,3	95,8	87,1	105,7	96,9
HTG-A96421-901	248,9	174,7	256,6	256,6	256,6	115,9	99,8	123,4	101,3	95,8	87,1	105,7	96,9
HTG-A96170-901	353,5	248,2	364,7	364,7	364,7	115,9	99,8	123,4	101,3	95,8	87,1	105,7	96,9
HTG-A96210-901	392,7	276,2	405,7	405,7	405,7	115,9	99,8	123,4	101,3	95,8	87,1	105,7	96,9
HTG-B44050-901	65,5	45,9	67,6	67,6	67,6	173,9	149,9	185,1	152,0	143,6	130,5	158,6	145,4
HTG-B44070-901	104,7	73,5	108,2	108,2	108,2	173,9	149,9	185,1	152,0	143,6	130,5	158,6	145,4
HTG-B44090-901	150,5	105,7	155,4	155,4	155,4	173,9	149,9	185,1	152,0	143,6	130,5	158,6	145,4
HTG-B44281-901	150,5	105,7	155,4	155,4	155,4	173,9	149,9	185,1	152,0	143,6	130,5	158,6	145,4
HTG-B44110-901	202,7	142,5	209,3	209,3	209,3	173,9	149,9	185,1	152,0	143,6	130,5	158,6	145,4
HTG-B44130-901	248,9	174,7	256,6	256,6	256,6	173,9	149,9	185,1	152,0	143,6	130,5	158,6	145,4
HTG-B44421-901	248,9	174,7	256,6	256,6	256,6	173,9	149,9	185,1	152,0	143,6	130,5	158,6	145,4
HTG-B44170-901	353,5	248,2	364,7	364,7	364,7	173,9	149,9	185,1	152,0	143,6	130,5	158,6	145,4
HTG-B44210-901	392,7	276,2	405,7	405,7	405,7	173,9	149,9	185,1	152,0	143,6	130,5	158,6	145,4
HTG-B92050-901	65,5	45,9	67,6	67,6	67,6	231,9	199,9	246,8	202,6	191,5	174,0	211,5	193,8
HTG-B92070-901	104,7	73,5	108,2	108,2	108,2	231,9	199,9	246,8	202,6	191,5	174,0	211,5	193,8
HTG-B92090-901	150,5	105,7	155,4	155,4	155,4	231,9	199,9	246,8	202,6	191,5	174,0	211,5	193,8
HTG-B92281-901	150,5	105,7	155,4	155,4	155,4	231,9	199,9	246,8	202,6	191,5	174,0	211,5	193,8
HTG-B92110-901	202,7	142,5	209,3	209,3	209,3	231,9	199,9	246,8	202,6	191,5	174,0	211,5	193,8
HTG-B92130-901	248,9	174,7	256,6	256,6	256,6	231,9	199,9	246,8	202,6	191,5	174,0	211,5	193,8
HTG-B92421-901	248,9	174,7	256,6	256,6	256,6	231,9	199,9	246,8	202,6	191,5	174,0	211,5	193,8
HTG-B92170-901	353,5	248,2	364,7	364,7	364,7	231,9	199,9	246,8	202,6	191,5	174,0	211,5	193,8
HTG-B92210-901	392,7	276,2	405,7	405,7	405,7	231,9	199,9	246,8	202,6	191,5	174,0	211,5	193,8

Note: 1. The data reported in the Table 2 and 3 is based on filter driers in a clean system at ideal conditions; with impurities accumulated in the filter, the capacity may decrease.
 2. R407C data based on dew point conditions

HTG SERIES

Filter Driers with Replaceable Core

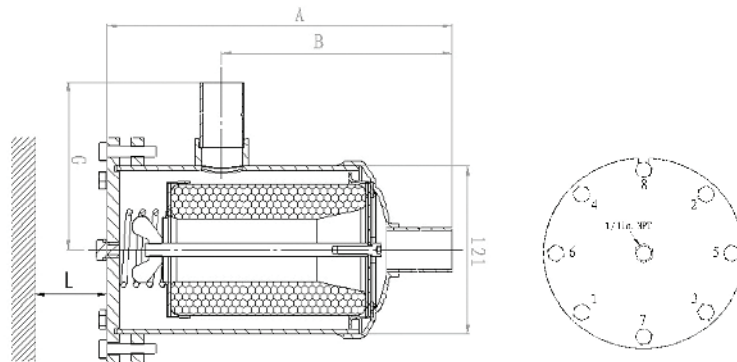

SELECTION FORMULAS

Filter driers for liquid line are manufactured in compliance with ARI Standard 710. Maximum flow rate of liquid refrigerant at a differential pressure of 0,07bar (1psi) is indicated by kW (ton) which is based on the temperature of liquid refrigerant 30°C (86°F), the evaporating temperature of -15°C (5°F) and the following mass flow:

- 0,40 kg/min/kW (3.1 lb/min/ton) R134a
- 0,53 kg/min/kW (4.1 lb/min/ton) R404A, R507A
- 0,39 kg/min/kW (3.0 lb/min/ton) R22, R407C
- 0,36 kg/min/kW (2.8 lb/min/ton) R410A

Note: Data on water absorption is based on the following EPD (method: ASHRAE Standard 63.1):

- 60ppm R22
- 50ppm R134a
- 50ppm R404A
- 50ppm R407C
- 50ppm R410A
- 50ppm R507A



HI I'M SOLY, THE SANHUA SOLENOID VALVE, I CAN HELP YOU TO FIND SANHUA'S BEST SOLUTION FOR YOU



SELECTION TOOL

SANHUA Selection Tool gives you the possibility to identify the best component suitable in our range which covers your system requirement.

DOWNLOAD it and make your system design easy using this intuitive Sanhua Tool.





CROSS REFERENCE TOOL

SANHUA with the collaboration of his dealers and technical team makes you easy to identify our products compared to other components and brands in the market.

Don't forget to double check if our suggestion covers your entire requirements.





sanhuaeurope.com

CHILLING
IDEAS
WORLDWIDE

SANHUA
SINCE 1984

 **SANHUA**

SANHUA INTERNATIONAL EUROPE
info@sanhuaeurope.com

